

ABBREVIATIONS

AB	Air Brick	DP	Down Pipe	PRF	Post & Rail Fence
B	Blind or Bottom Height	EL	Even Level	PWF	Post & Wire Fence
BB	Belted Beacon	ELEC	Electricity	R	Render
BD	Back Drop	EP	Electricity Pole	RAD	Road
BH	Borehole or Beam Height	FB	Flower Bed	RC	Rodding Eye
BL	Back Level	FL	Floor Level	RG	Rough Ground
BP	Back Pavers	FL	Floor Level	RL	Ridge Level
BRW	Brick Retaining Wall	FR	Flat Roof Level	RSP	Road Sign
BS	Bus Stop	G	Gully	RWP	Rain Water Pipe
BT	Brick Tarmac	GV	Gas Valve	SC	Stop Cock
BW	Brick Wall	H	Height in Metres	SC	Stop Valve
BT	Brick Tarmac	HT	Height	SL	Soft Level or Slight
CB	Control Box	HT	Height	SP	Arch Springing Height
CBF	Close Boarded Fence	IC	Insulation Cover	SPS	Stone Paving Slabs
CBW	Concrete Block Wall	IL	Inset Level	SW	Stone Wall
CCB	Cast Concrete Block	IRF	Iron Rolling Fence	TB	Telecoms Box
CCD	Cast Concrete Drain	IF	Inlet Fence	TCSU	Traffic Control
CD	Channel Drain	KO	Kerf Outlet	TL	Traffic Light
CF	Cast in Place Concrete	L	Light	TP	Telephone Pole
CF	Cast in Place Concrete	LP	Lamp Post	TPF	Timber Panel Fence
CF	Cast in Place Concrete	MH	Manhole	TPS	Tactile Paving Slabs
CL	Chain Link Fence	MKR	Marker	UTL	Unable to L/R
CLF	Concrete Panel Fence	O/H	Overhead	V	Vent
CLF	Concrete Panel Fence	O/H	Overhead	VP	Vent Pipe
CLF	Concrete Panel Fence	O/H	Overhead	W	Window
CPS	Arch Crown Height	P	Post	WM	Water Meter
CRW	Concrete Retaining Wall	PALF	Palisade Fence	WM	Water Meter
CSU	Cable Slips Lip	PAR	Parade Fence	WV	Wire Mesh Fence
CTV	Cable Television	PIT	Pit	WV	Wire Mesh Fence
CW	Concrete Wall	PL	Pavement Light	WV	Wire Mesh Fence
D	Diameter or Doors	PM	Parking Meter	WV	Wire Mesh Fence

LEVEL NOTE.
ALL LEVELS RELATE TO OSBM LOCATED ON No. 18 WILLOW HOUSE, SALISBURY SQUARE VALUE = 72.70m

CONTROL SCHEDULE

STN	EASTING	NORTHING	LEVEL
101	44.050	132.811	77.984
102	18.532	114.316	78.101
103	72.064	120.796	79.953
301	9.970	112.333	75.010
302	30.162	103.557	79.129
303	10.967	88.950	78.486
304	35.815	72.830	77.416
305	105.887	77.000	78.486
306	94.189	77.582	81.644
307	105.709	83.991	85.314
308	137.517	23.591	85.315
309	232.453	23.628	81.438
314	52.752	83.864	78.316
315	95.908	55.920	79.849

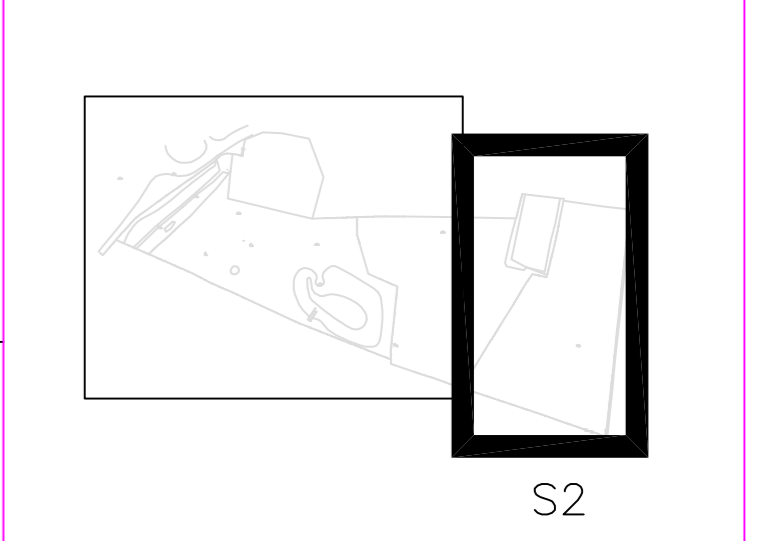
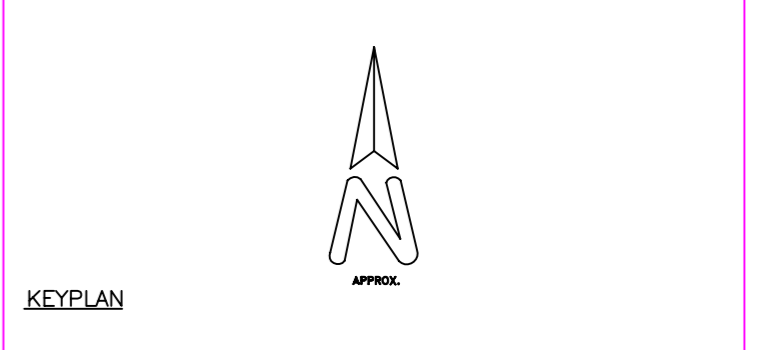

REVISIONS

Revisions	Date
B HORIZONTAL AND VERTICAL CONTROL CHANGED TO MATCH HATFIELD OLD TOWN SURVEY, DWG No. 08501-S1	27/6/2008
A SURROUNDING AREA SURVEYED	20/3/2008

Client
GASCOYNE CECIL ESTATES

Dwg. Title
LAND SURVEY

Project Title
ST AUDREY'S CAR PARK
HATFIELD, HERTS

Scale 1:200
Checked JGR
Drawn SD

Date MAR 2008
Job No. 04902

Client
GASCOYNE CECIL ESTATES

Dwg. Title
LAND SURVEY

Project Title
ST AUDREY'S CAR PARK
HATFIELD, HERTS

Scale 1:200
Checked JGR
Drawn SD

Date MAR 2008
Job No. 04902

Client
GASCOYNE CECIL ESTATES

Dwg. Title
LAND SURVEY

Project Title
ST AUDREY'S CAR PARK
HATFIELD, HERTS

Scale 1:200
Checked JGR
Drawn SD

Date MAR 2008
Job No. 04902

Client
GASCOYNE CECIL ESTATES

Dwg. Title
LAND SURVEY

Project Title
ST AUDREY'S CAR PARK
HATFIELD, HERTS

Scale 1:200
Checked JGR
Drawn SD

Date MAR 2008
Job No. 04902

Client
GASCOYNE CECIL ESTATES

Dwg. Title
LAND SURVEY

Project Title
ST AUDREY'S CAR PARK
HATFIELD, HERTS

Scale 1:200
Checked JGR
Drawn SD

Date MAR 2008
Job No. 04902

Client
GASCOYNE CECIL ESTATES

Dwg. Title
LAND SURVEY

Project Title
ST AUDREY'S CAR PARK
HATFIELD, HERTS

Scale 1:200
Checked JGR
Drawn SD

Date MAR 2008
Job No. 04902

Client
GASCOYNE CECIL ESTATES

Dwg. Title
LAND SURVEY

Project Title
ST AUDREY'S CAR PARK
HATFIELD, HERTS

Scale 1:200
Checked JGR
Drawn SD

Date MAR 2008
Job No. 04902

Client
GASCOYNE CECIL ESTATES

Dwg. Title
LAND SURVEY

Project Title
ST AUDREY'S CAR PARK
HATFIELD, HERTS

Scale 1:200
Checked JGR
Drawn SD

Date MAR 2008
Job No. 04902

Client
GASCOYNE CECIL ESTATES

Dwg. Title
LAND SURVEY

Project Title
ST AUDREY'S CAR PARK
HATFIELD, HERTS

Scale 1:200
Checked JGR
Drawn SD

Date MAR 2008
Job No. 04902

Client
GASCOYNE CECIL ESTATES

Dwg. Title
LAND SURVEY

Project Title
ST AUDREY'S CAR PARK
HATFIELD, HERTS

Scale 1:200
Checked JGR
Drawn SD

Date MAR 2008
Job No. 04902

Client
GASCOYNE CECIL ESTATES

Dwg. Title
LAND SURVEY

Project Title
ST AUDREY'S CAR PARK
HATFIELD, HERTS

Scale 1:200
Checked JGR
Drawn SD

Date MAR 2008
Job No. 04902

Client
GASCOYNE CECIL ESTATES

Dwg. Title
LAND SURVEY

Project Title
ST AUDREY'S CAR PARK
HATFIELD, HERTS

Scale 1:200
Checked JGR
Drawn SD

Date MAR 2008
Job No. 04902

Client
GASCOYNE CECIL ESTATES

Dwg. Title
LAND SURVEY

Project Title
ST AUDREY'S CAR PARK
HATFIELD, HERTS

Scale 1:200
Checked JGR
Drawn SD

Date MAR 2008
Job No. 04902

Client
GASCOYNE CECIL ESTATES

Dwg. Title
LAND SURVEY

Project Title
ST AUDREY'S CAR PARK
HATFIELD, HERTS

Scale 1:200
Checked JGR
Drawn SD

Date MAR 2008
Job No. 04902

Client
GASCOYNE CECIL ESTATES

Dwg. Title
LAND SURVEY

Project Title
ST AUDREY'S CAR PARK
HATFIELD, HERTS

Scale 1:200
Checked JGR
Drawn SD

Date MAR 2008
Job No. 04902

Client
GASCOYNE CECIL ESTATES

Dwg. Title
LAND SURVEY

Project Title
ST AUDREY'S CAR PARK
HATFIELD, HERTS

Scale 1:200
Checked JGR
Drawn SD

Date MAR 2008
Job No. 04902

Client
GASCOYNE CECIL ESTATES

Dwg. Title
LAND SURVEY

Project Title
ST AUDREY'S CAR PARK
HATFIELD, HERTS

Scale 1:200
Checked JGR
Drawn SD

Date MAR 2008
Job No. 04902

Client
GASCOYNE CECIL ESTATES

Dwg. Title
LAND SURVEY

Project Title
ST AUDREY'S CAR PARK
HATFIELD, HERTS

Scale 1:200
Checked JGR
Drawn SD

Date MAR 2008
Job No. 04902

Client
GASCOYNE CECIL ESTATES

Dwg. Title
LAND SURVEY

Project Title
ST AUDREY'S CAR PARK
HATFIELD, HERTS

Scale 1:200
Checked JGR
Drawn SD

Date MAR 2008
Job No. 04902

Client
GASCOYNE CECIL ESTATES

Dwg. Title
LAND SURVEY

Project Title
ST AUDREY'S CAR PARK
HATFIELD, HERTS

Scale 1:200
Checked JGR
Drawn SD

Date MAR 2008
Job No. 04902

Client
GASCOYNE CECIL ESTATES

Dwg. Title
LAND SURVEY

Project Title
ST AUDREY'S CAR PARK
HATFIELD, HERTS

Scale 1:200
Checked JGR
Drawn SD

Date MAR 2008
Job No. 04902

Client
GASCOYNE CECIL ESTATES

Dwg. Title
LAND SURVEY

Project Title
ST AUDREY'S CAR PARK
HATFIELD, HERTS

Scale 1:200
Checked JGR
Drawn SD

Date MAR 2008
Job No. 04902

Client
GASCOYNE CECIL ESTATES

Dwg. Title
LAND SURVEY

Project Title
ST AUDREY'S CAR PARK
HATFIELD, HERTS

Scale 1:200
Checked JGR
Drawn SD

Date MAR 2008
Job No. 04902

Client
GASCOYNE CECIL ESTATES

Dwg. Title
LAND SURVEY

Project Title
ST AUDREY'S CAR PARK
HATFIELD, HERTS

Scale 1:200
Checked JGR
Drawn SD

Date MAR 2008
Job No. 04902

Client
GASCOYNE CECIL ESTATES

Dwg. Title
LAND SURVEY

Project Title
ST AUDREY'S CAR PARK
HATFIELD, HERTS

Scale 1:200
Checked JGR
Drawn SD

Date MAR 2008
Job No. 04902

Client
GASCOYNE CECIL ESTATES

Dwg. Title
LAND SURVEY

Project Title
ST AUDREY'S CAR PARK
HATFIELD, HERTS

Scale 1:200
Checked JGR
Drawn SD

Date MAR 2008
Job No. 04902

Client
GASCOYNE CECIL ESTATES

Dwg. Title
LAND SURVEY

Project Title
ST AUDREY'S CAR PARK
HATFIELD, HERTS

Scale 1:200
Checked JGR
Drawn SD

Date MAR 2008
Job No. 04902

Client
GASCOYNE CECIL ESTATES

Dwg. Title
LAND SURVEY

Project Title
ST AUDREY'S CAR PARK
HATFIELD, HERTS

Scale 1:200
Checked JGR
Drawn SD

Date MAR 2008
Job No. 04902

Client
GASCOYNE CECIL ESTATES

Dwg. Title
LAND SURVEY

Project Title
ST AUDREY'S CAR PARK
HATFIELD, HERTS

Scale 1:200
Checked JGR
Drawn SD

Date MAR 2008
Job No. 04902

Client
GASCOYNE CECIL ESTATES

Dwg. Title
LAND SURVEY

Project Title
ST AUDREY'S CAR PARK
HATFIELD, HERTS

Scale 1:200
Checked JGR
Drawn SD

Date MAR 2008
Job No. 04902

Client
GASCOYNE CECIL ESTATES

Dwg. Title
LAND SURVEY

Project Title
ST AUDREY'S CAR PARK
HATFIELD, HERTS

Scale 1:200
Checked JGR
Drawn SD