

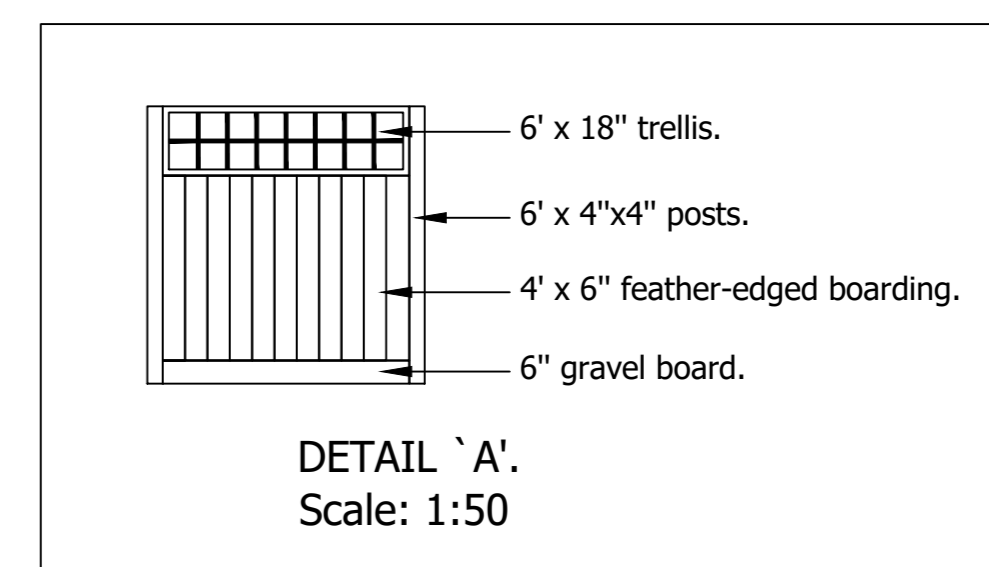

✕A	DENOTE BOUNDARY POINTS.
A to B	PLANTING AS SCHEDULE.
B to C	NEW VEHICULAR ACCESS.
C to D	NEW 1.2M HIGH PICKET FENCE.
D to E	NEW 1.2M HIGH PICKET FENCE. (EXISTING HEDGE REMOVED).
E to F	EXISTING BRICK WALL OF NEIGHBOURING OUTBUILDING.
F to G	NEW 1.8M HIGH CLOSEBOARD FENCE.
G to H	NEW 1.8M HIGH CLOSEBOARD FENCE.
H to J	NEW 1.8M HIGH CLOSEBOARD FENCE.
J to A	NEW 1.8M HIGH FENCE AS DETAIL 'A'.

REF.	PROPOSED PLANTING SCHEDULE.
1	Weigela 'Florida Variegata'.
2	Ceanothus 'Thyrsiflorus repens'.
3	Senicio greyi.
4	Fuchsia magellanica 'Riccartonii'.
5	Spirea Anthony Waterer
6	Leycesteria formosa
7	Potentilla fruticosa 'Elizabeth'
8	Fuchsia magellanica 'Riccartonii'.
9	Deutzia x 'Rosea'
10	Cistus x purpureus
11	Leycesteria formosa
12	Choisya ternata 'Sundance'
13	Lavandula angustifolia 'Hidcote'
14	MIXED ROSE BUSHES: Hybrid Tea, Floribunda & Old English
15	Pyracantha
16	Climbing Rose
17	Clematis Montana 'Rubens'
18	Climbing Rose
19	Prunus Subhirtella 'Pendula Rubra'
20	Thuja Occidentalis (Hedge)



Rev.	Amendment Description	Date
PRELIMINARY		

title Site Layout. Proposed Landscaping.			
client Bricrest Homes Ltd.	job 34, Vineyards Rd.		rev.
date Jan. 2021	scale 1:100 @ A1	drg.no. L2006/01	P2
 architectural, development and sustainability consultants home energy rating and Code for Sustainable Homes Assessors www.tdcgroup.co.uk • enquiries@tdcgroup.co.uk 01763 273315 Hawthorn House, 92 Green Drift, Royston, Herts, SG8 5BT			

BIRD BOXES



BB1: 2GR Schwegler 3 Hole Nest Box. (2 No.)



BB2: Vivara Nesting Box 32mm. (2 No.)

INSECT BOXES



INS-1: Bee Nesting Box (2 No.)



INS-2: Insect Tower 21x65cm (2 No.)



INS-3: Woodstock Insect Block 9x18x26cm (2 No.)