

*A	DENOTE BOUNDARY POINTS.
A to B	PLANTING AS SCHEDULE.
B to C	NEW VEHICULAR ACCESS.
C to D	NEW 1.2M HIGH PICKET FENCE.
D to E	NEW 1.2M HIGH PICKET FENCE. (EXISTING HEDGE REMOVED).
E to F	EXISTING BRICK WALL OF NEIGHBOURING OUTBUILDING.
F to G	NEW 1.8M HIGH CLOSEBOARD FENCE.
G to H	NEW 1.8M HIGH CLOSEBOARD FENCE.
H to J	NEW 1.8M HIGH CLOSEBOARD FENCE.
J to A	NEW 1.8M HIGH FENCE AS DETAIL `A`.

PROPOSED PLANTING SCHEDULE.		
REF.	PLANT.	INFORMATION.
1	Weigela `Florida Variegata`.	1No. 45cm in 10L pot
2	Ceanothus `Thyrsiflorus repens`.	1No. 45cm in 10L pot
3	Senicio greyi.	1No. 45cm in 10L pot
4	Fuchsia magellanica `Riccartonii`.	1No. 45cm in 10L pot
5	Spirea Anthony Waterer	1No. 45cm in 10L pot
6	Leycesteria formosa	1No. 45cm in 10L pot
7	Potentilla fruticosa `Elizabeth`	1No. 45cm in 10L pot
8	Fuchsia magellanica `Riccartonii`.	1No. 45cm in 10L pot
9	Deutzia x `Rosea`	1No. 45cm in 10L pot
10	Cistus x purpureus	1No. 45cm in 10L pot
11	Leycesteria formosa	1No. 45cm in 10L pot
12	Choisya ternata `Sundance`	1No. 45cm in 10L pot
13	Lavandula angustifolia `Hidcote`	1No. 45cm in 10L pot
14	MIXED ROSE BUSHES: Hybrid Tea, Floribunda & Old English	1No. 45cm in 10L pot
15	Pyracantha	1No. 45cm in 10L pot
16	Climbing Rose	1No. 45cm in 10L pot
17	Clematis Montana `Rubens`	1No. 45cm in 10L pot
18	Climbing Rose	1No. 45cm in 10L pot
19	Prunus Subhirtella `Pendula Rubra`	1No. bare root 3m high
20	Thuja Occidentalis (Hedge)	10No. 1.5m high in 20L pots.

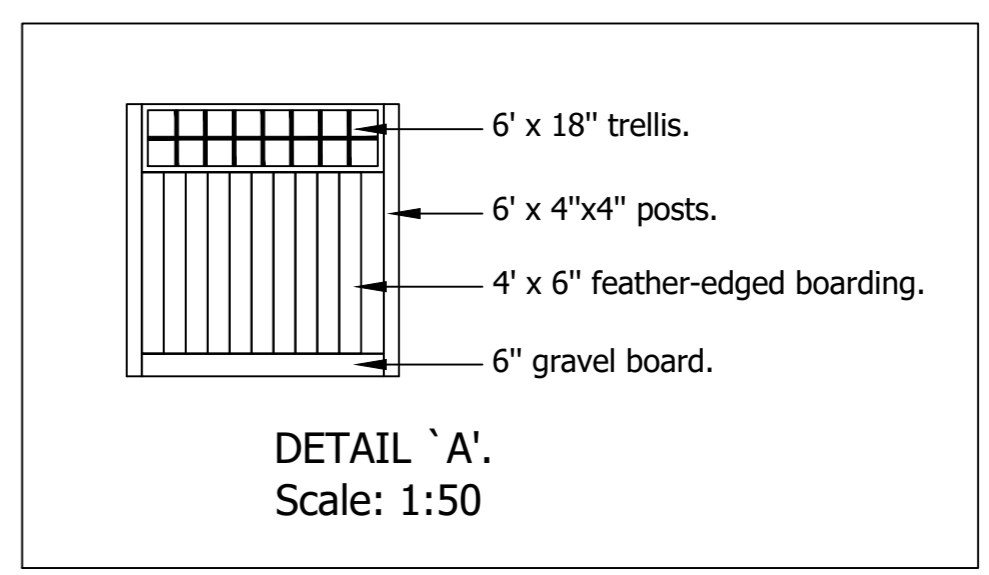

Rev.	Amendment Description	Date
A	Planting schedule amended. Bat box note added to existing trees.	19.04.2021

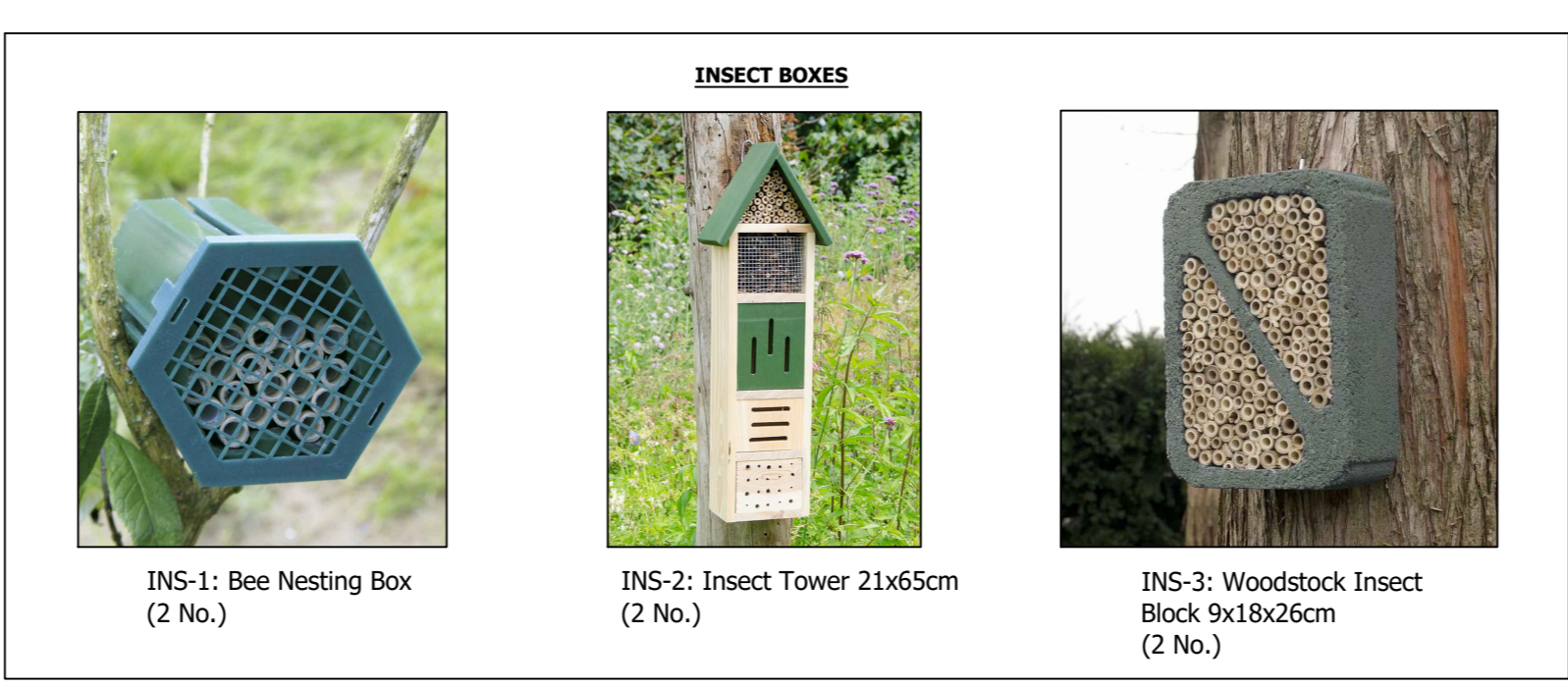
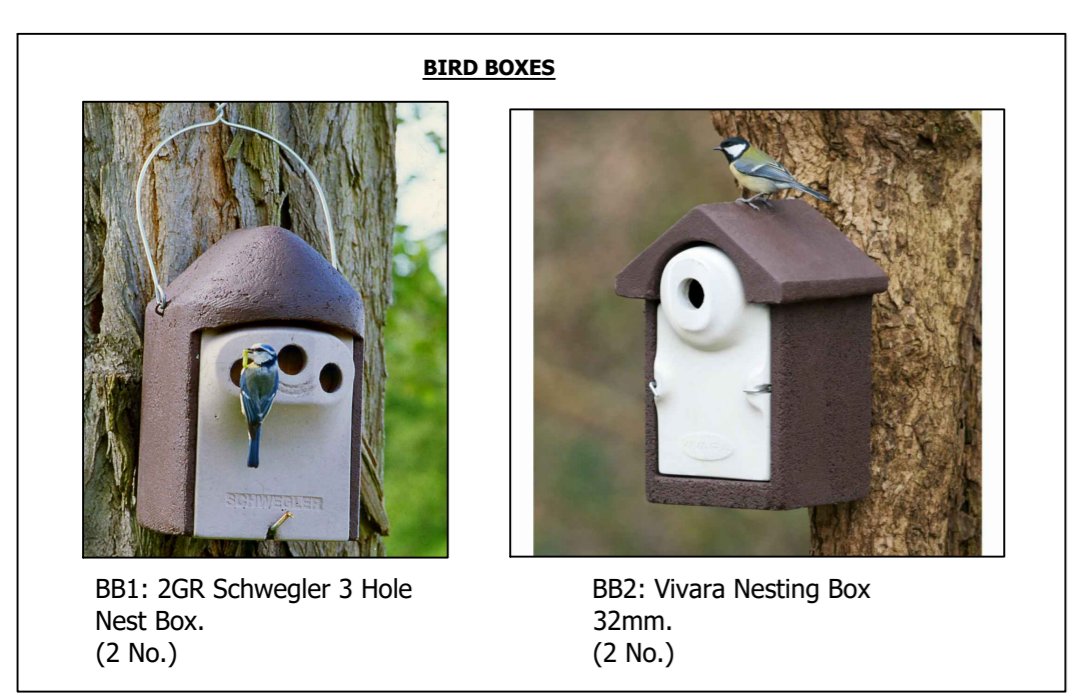

Site Layout.
Proposed Landscaping.

client: Bricrest Homes Ltd. job: 34, Vineyards Rd.

date: Jan. 2021 scale: 1:100 @ A1 drg.no: L2006/01 rev: A

tdc architectural, development and sustainability consultants
home energy rating and Code for Sustainable Homes Assessors
www.tdcgroup.co.uk • enquiries@tdcgroup.co.uk
01763 273315
Hawthorn House, 92 Green Drift, Royston, Herts, SG8 5BT