

EXISTING GROUND FLOOR PLAN

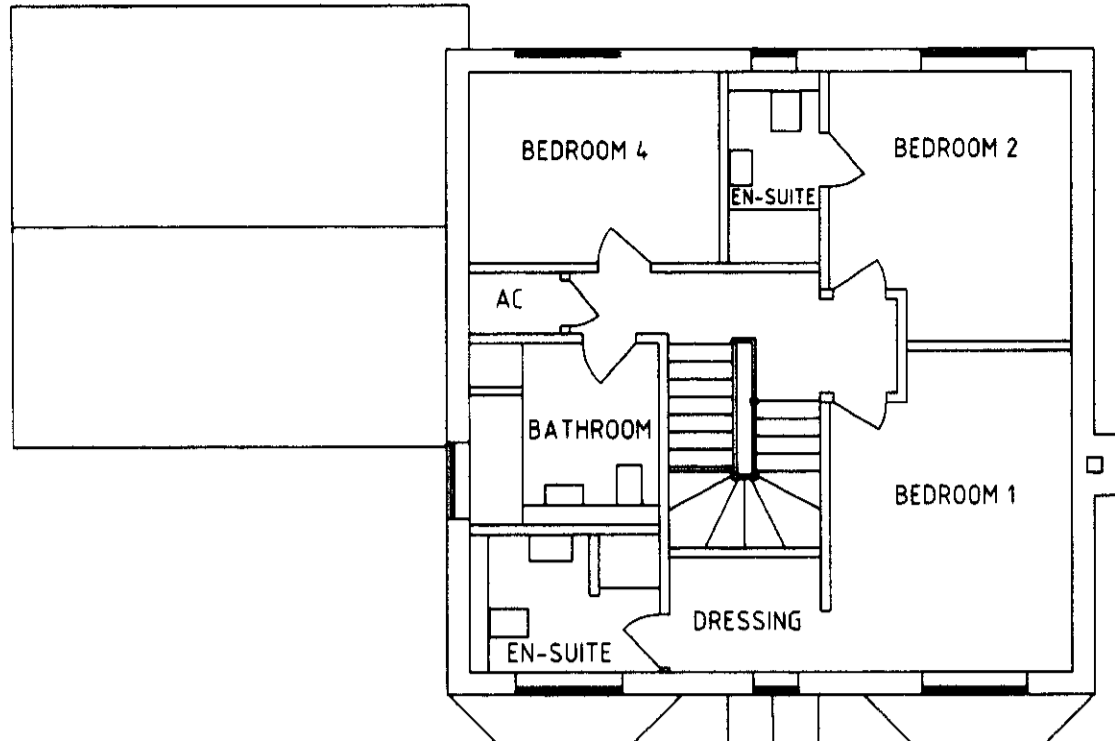

EXISTING FIRST FLOOR PLAN

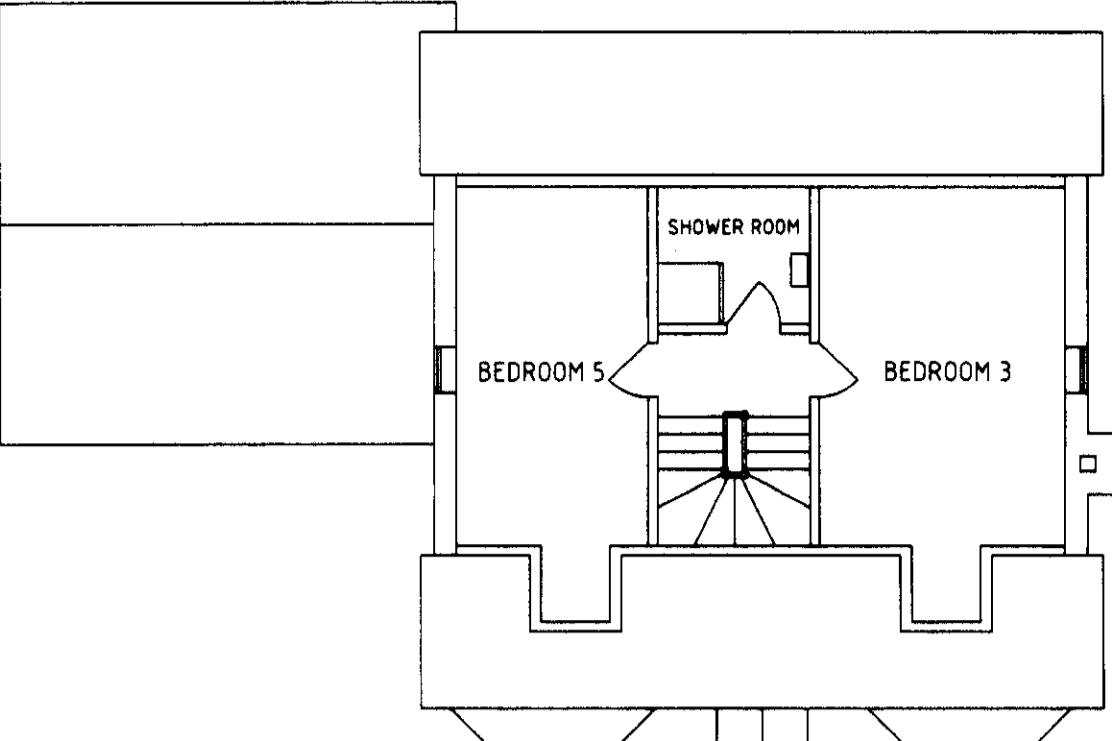

EXISTING SECOND FLOOR PLAN

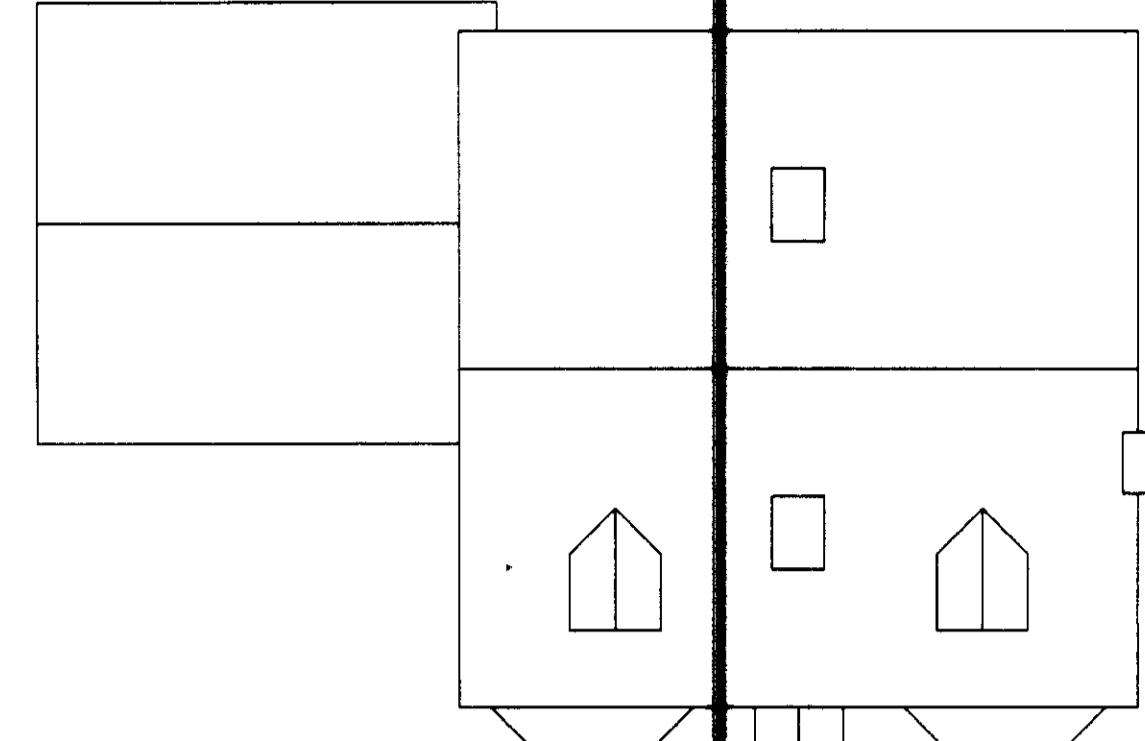

EXISTING ROOF PLAN



EXISTING SIDE ELEVATION



EXISTING FRONT ELEVATION

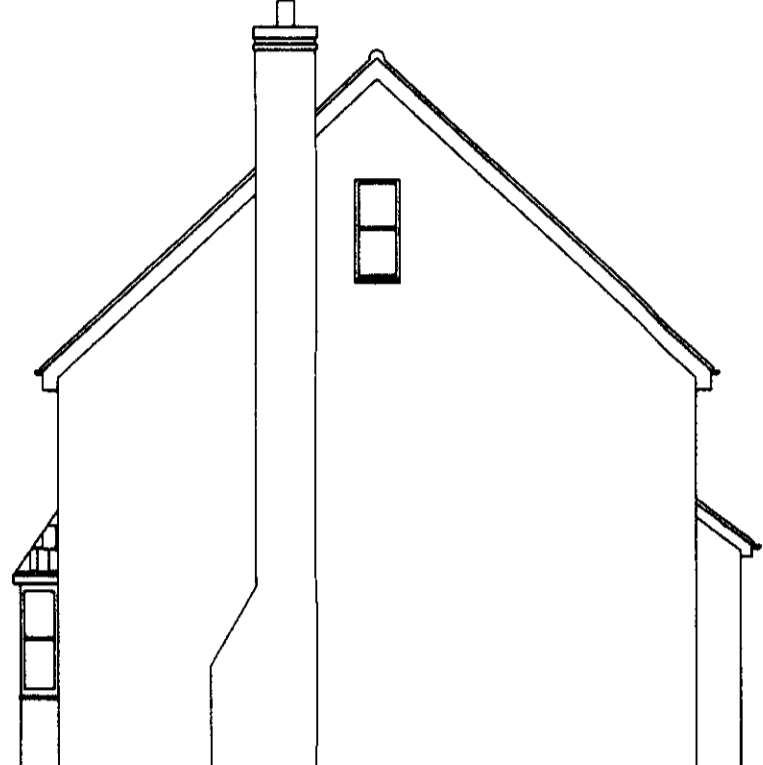

EXISTING SIDE ELEVATION

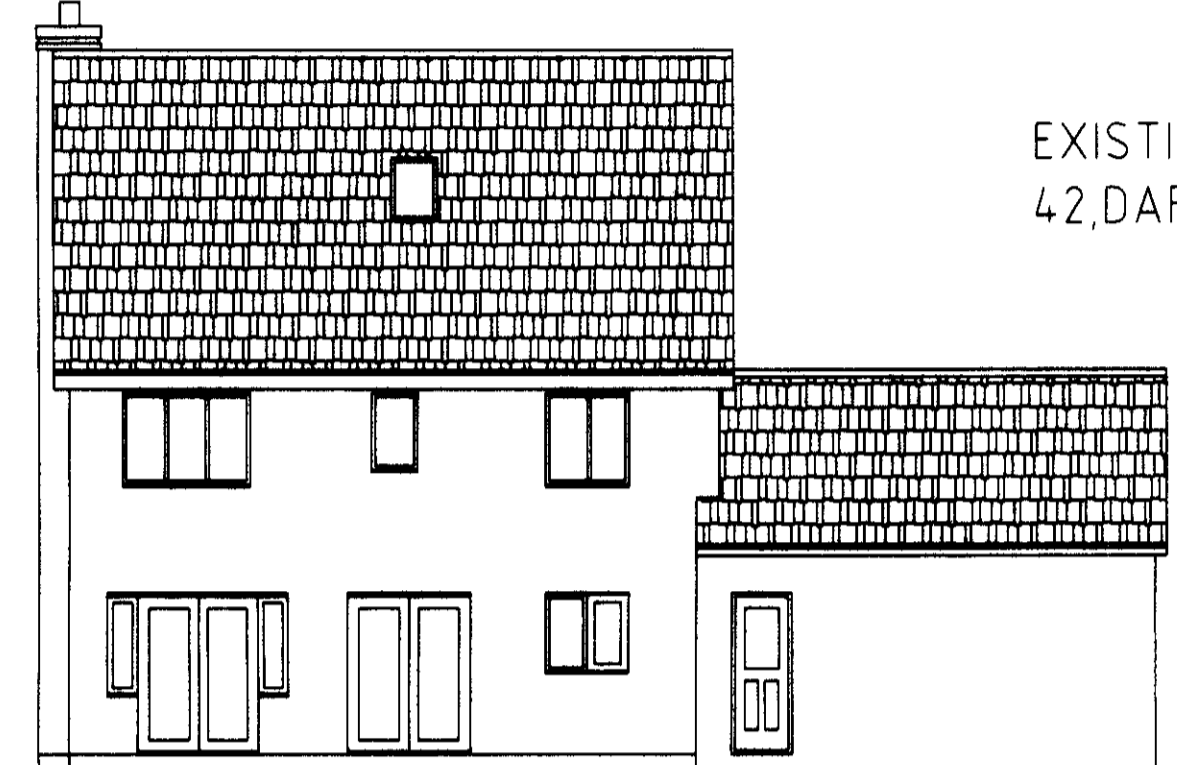

EXISTING REAR ELEVATION

EXISTING DETACHED HOUSE
42, DAFFODIL CLOSE, HATFIELD, HERTS.

SUPERSEDED
28 JUN 2010
NO: 6

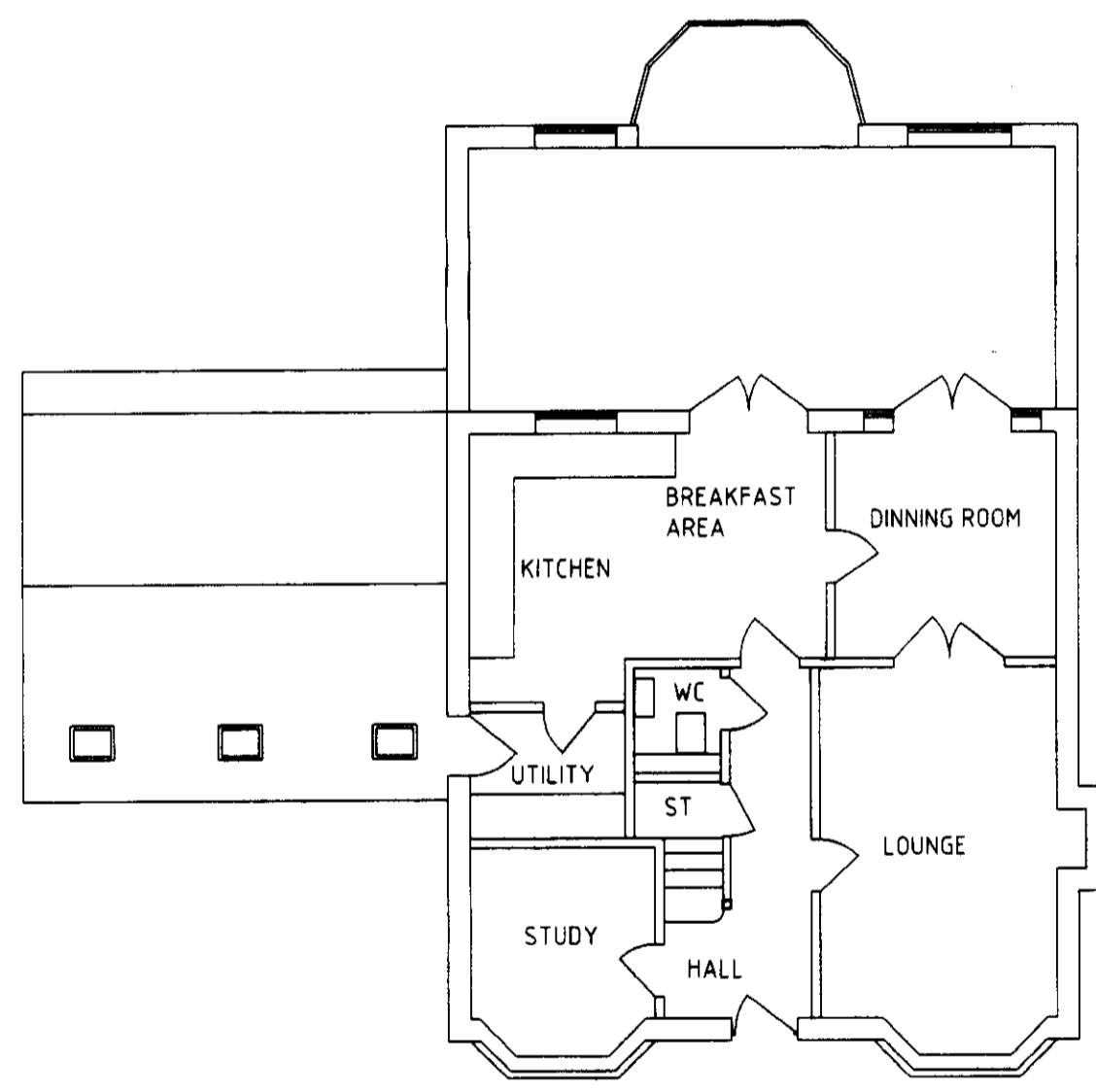

PROPOSED GROUND FLOOR PLAN

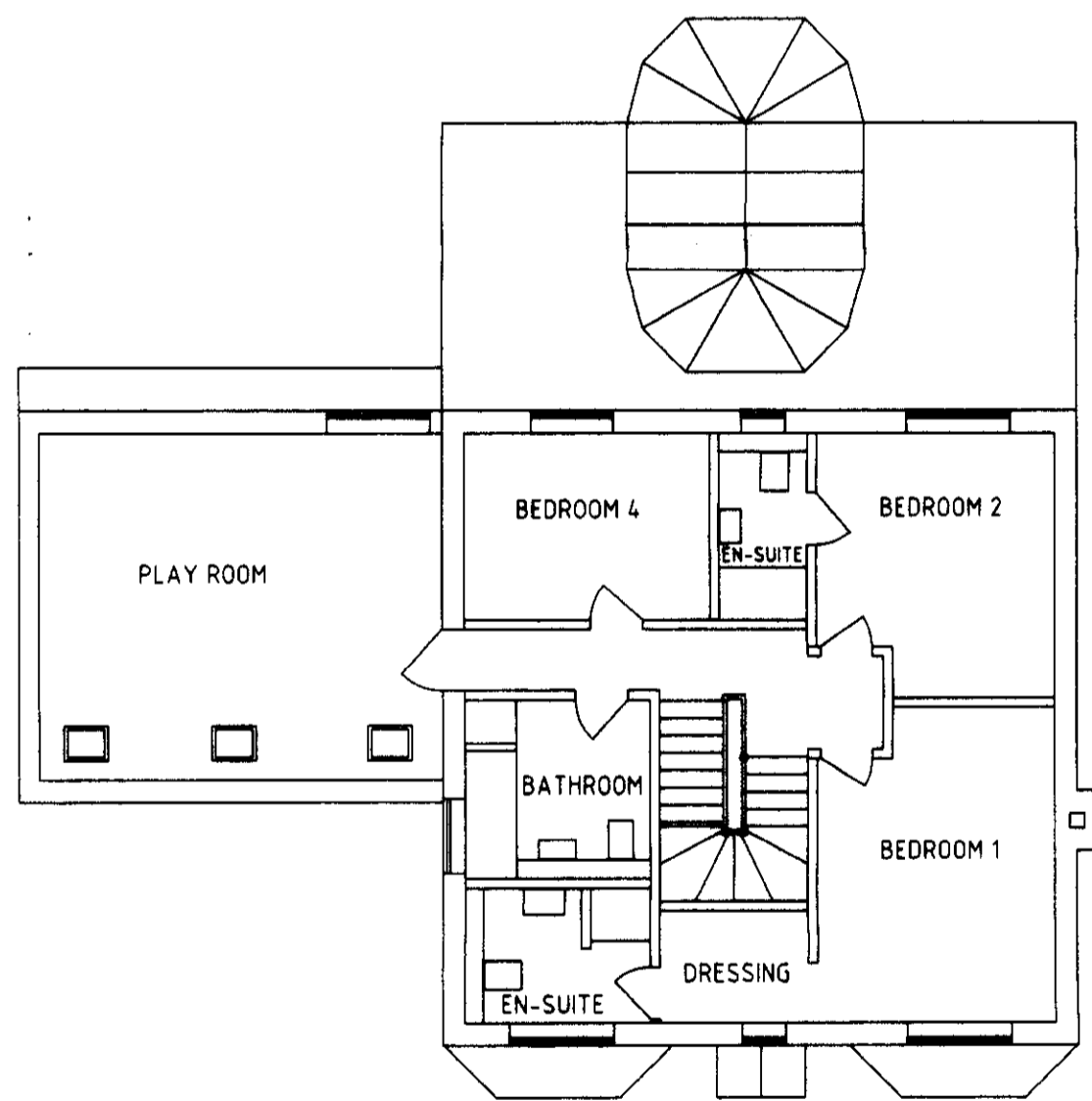

PROPOSED FIRST FLOOR PLAN

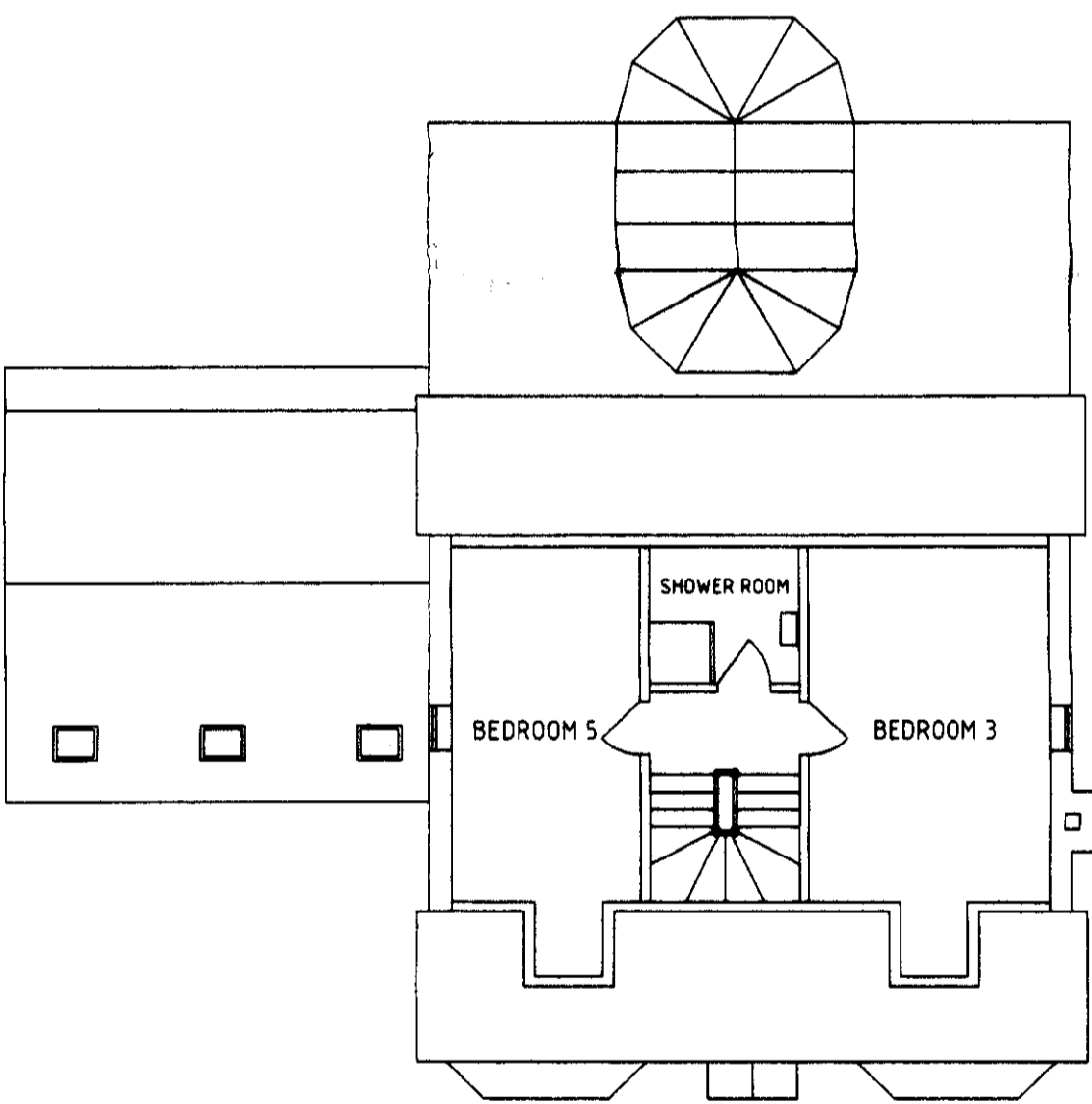

PROPOSED SECOND FLOOR PLAN

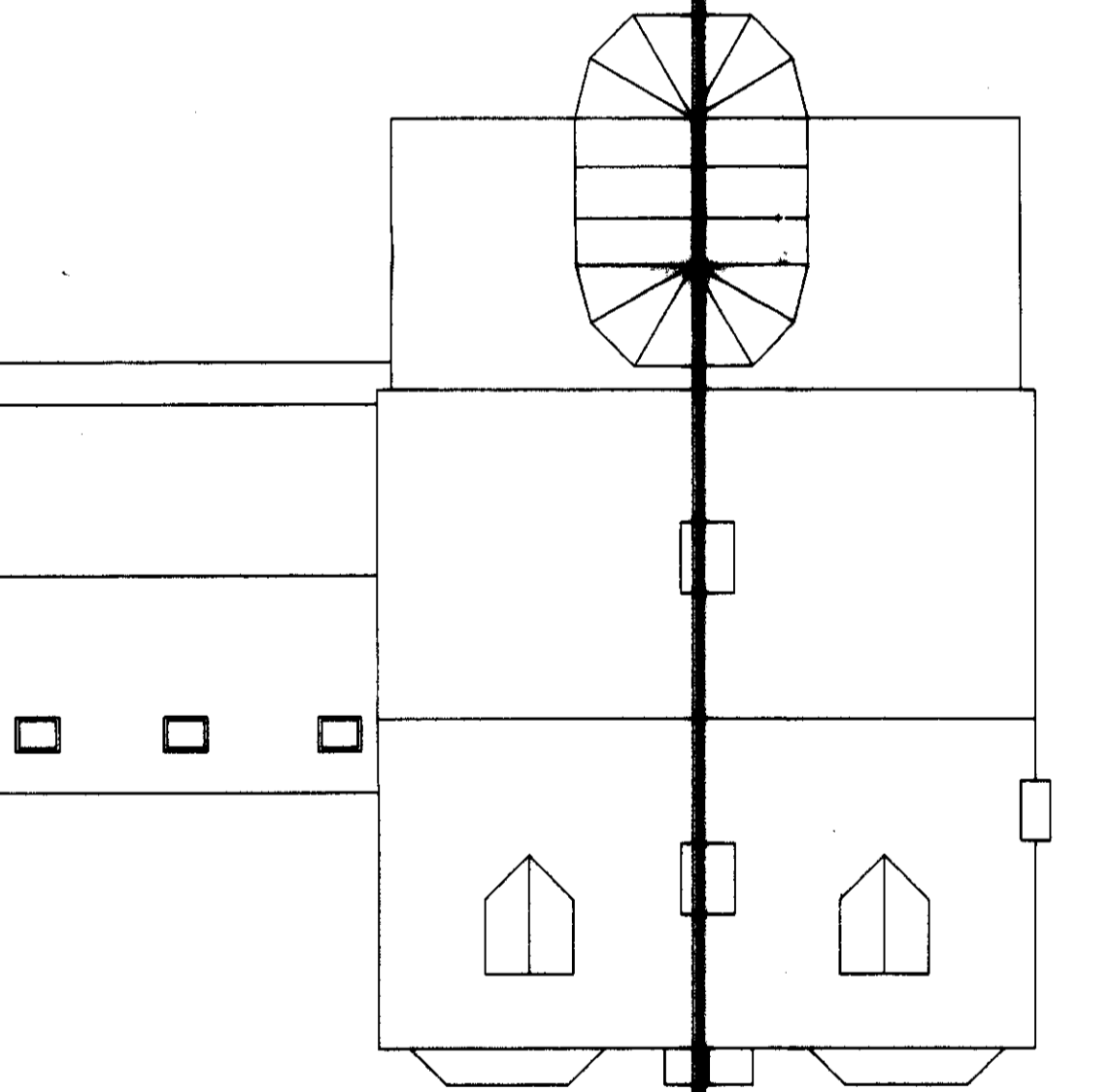

PROPOSED ROOF PLAN

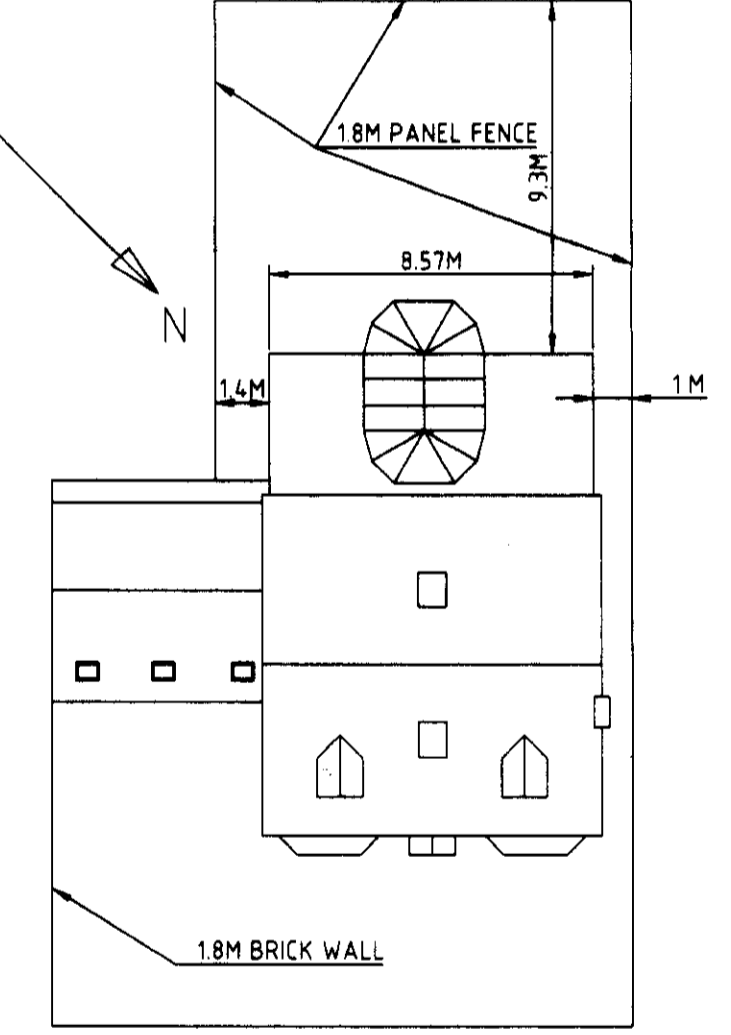

BLOCK PLAN
SCALE 1/200

*Conservatory: 4.6m in height
3.2m in width
5.3m in depth
Rear extension: 3.9m in height
3.7m in depth
8.6m in width*

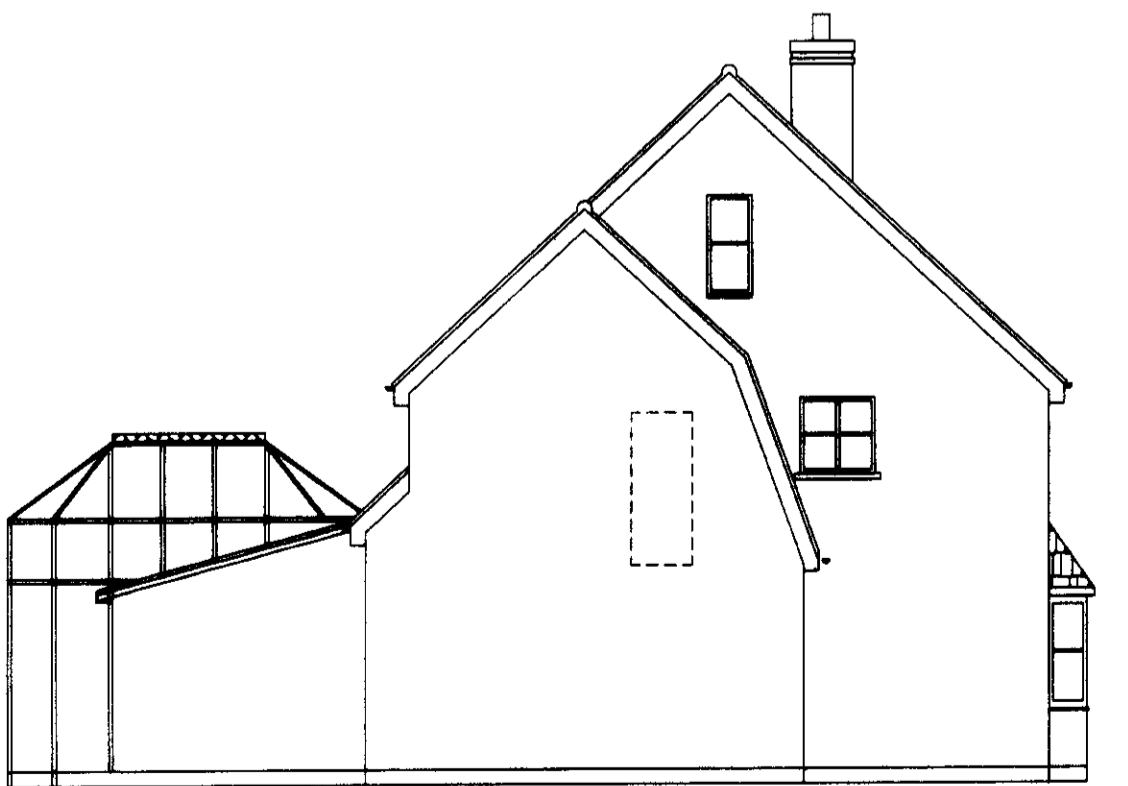

PROPOSED SIDE ELEVATION



PROPOSED FRONT ELEVATION

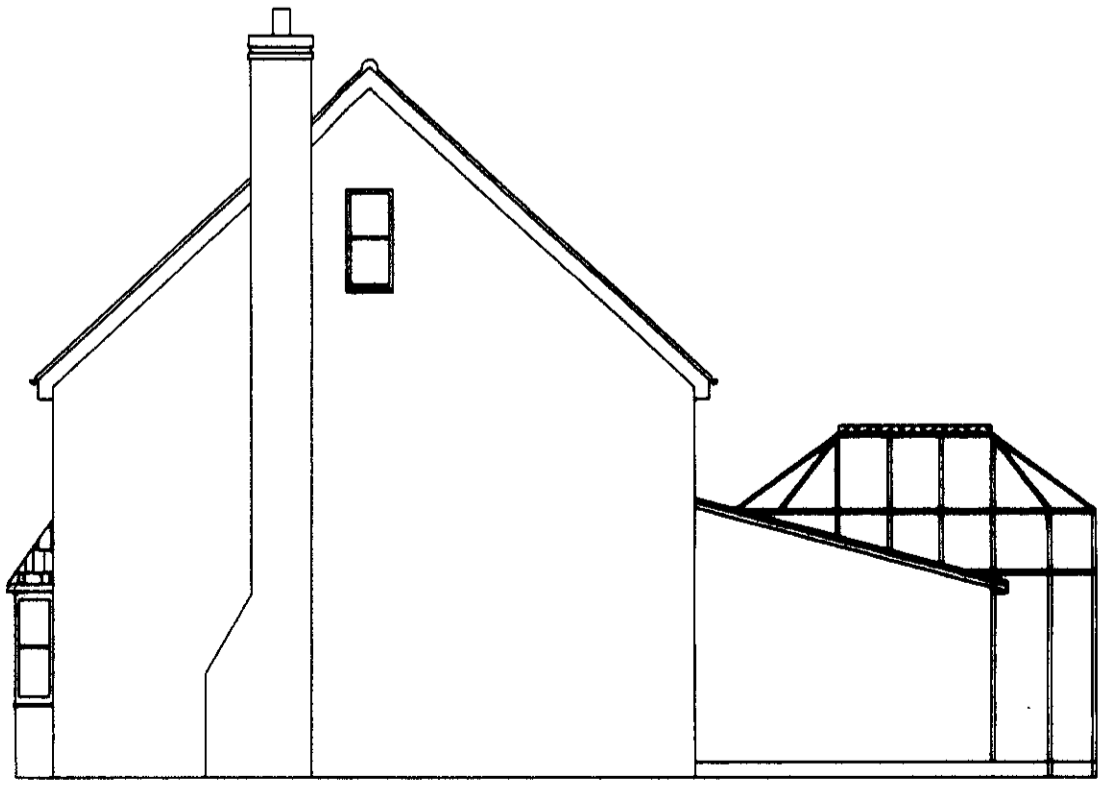

PROPOSED SIDE ELEVATION



PROPOSED REAR ELEVATION

PROPOSED EXTENSIONS OF 36.9M SQUARE EXTERNALLY
42, DAFFODIL CLOSE, HATFIELD, HERTS.

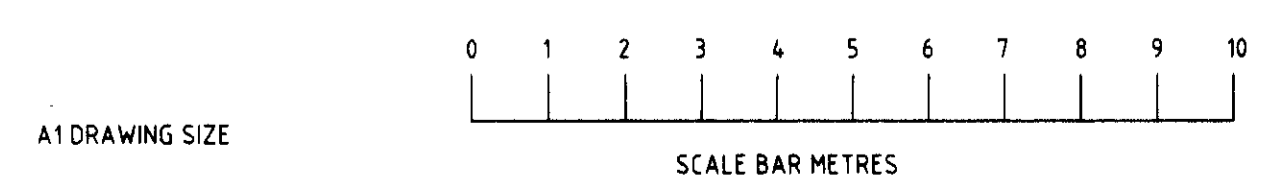

A1 DRAWING SIZE

SCALE BAR METRES

Itemref	Quantity	Title/Name, designation, material, dimension etc	Article No./Reference
Designed by JR	Checked by JR	Approved by - date	Filename 42,DAFFODILL
		Date 7/05/2010	Scale 1:100
MR. FAIZ-MAHMUD 42, DAFFODILL - CLOSE		EXTENSIONS	
		FM1	1 EDITION
			Sheet 1

WELWYN HATFIELD
PLANNING
OFFICE COPY
12 MAY 2010
No: 2010/132/FP