

# DOG KENNEL

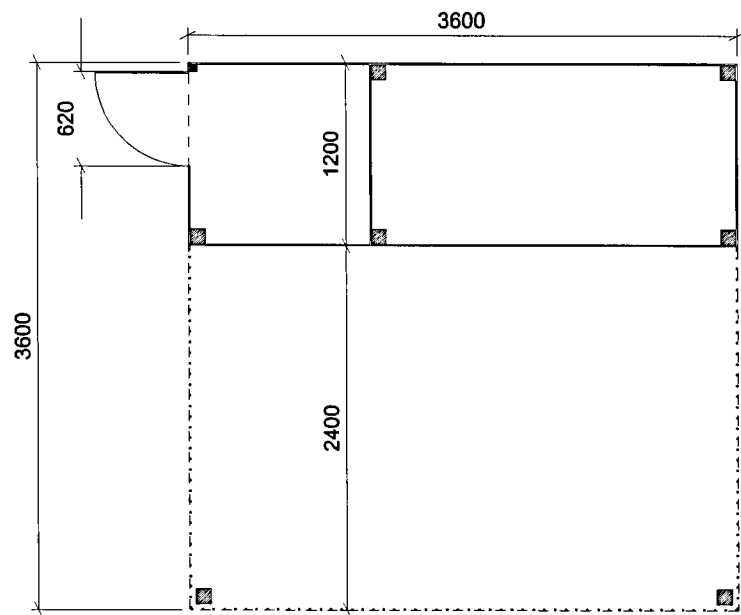

## FRONT ELEVATION

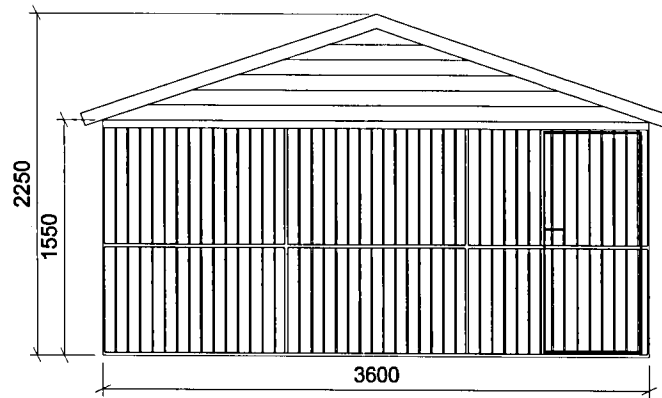

## EAST ELEVATION

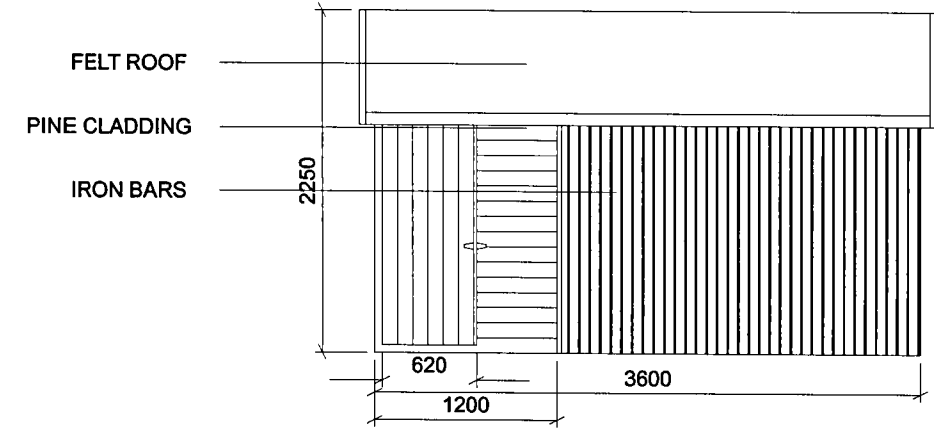

PLANNING  
DEPARTMENT  
OFFICE COPY  
  
11 MAY 2009  
  
NO 5:16/2009/0697/FP

## REAR ELEVATION

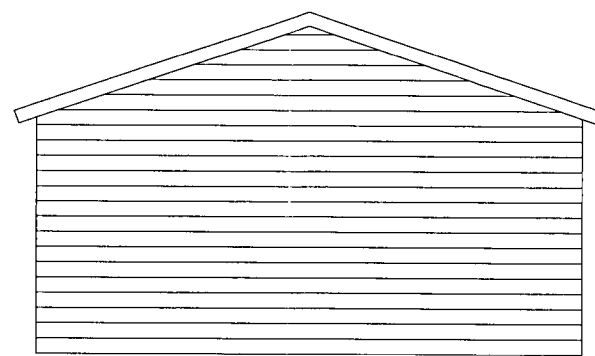

## WEST ELEVATION

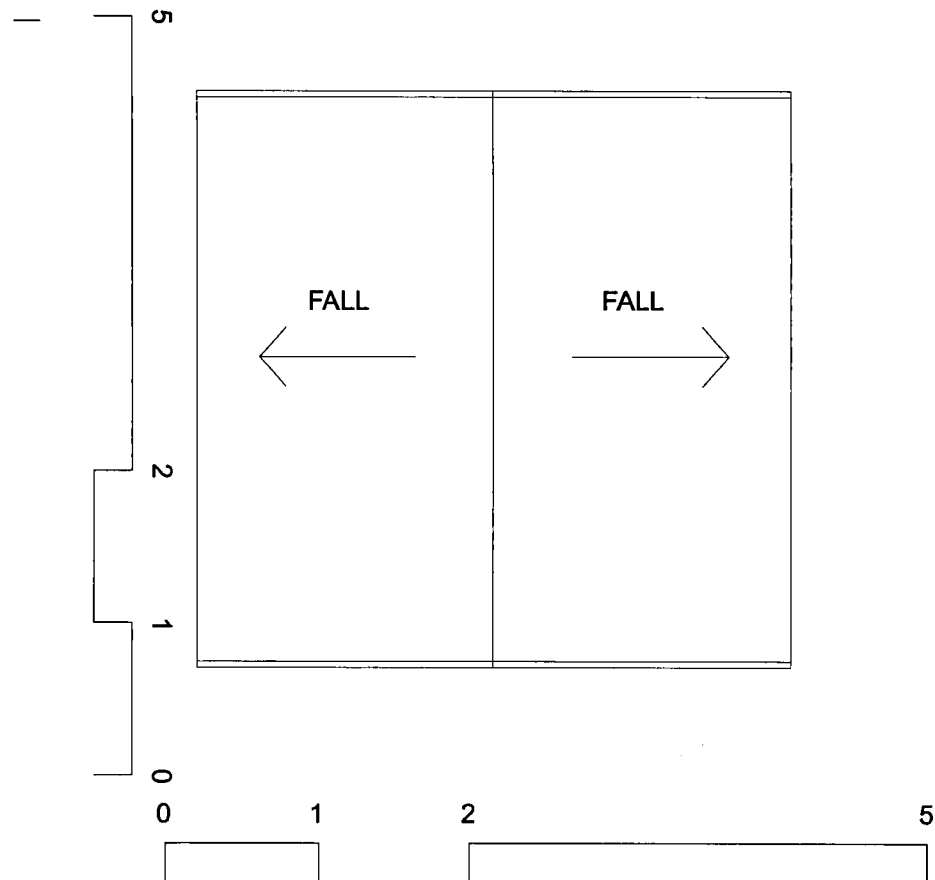
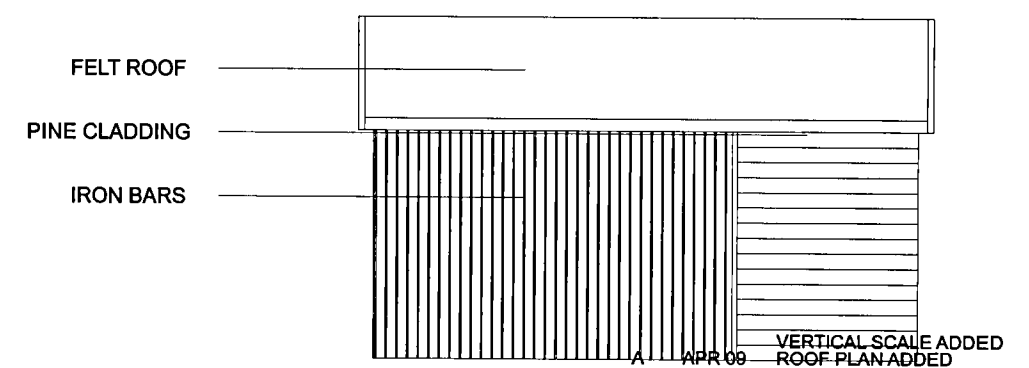

REV DATE DESCRIPTION

<b>GML Architects</b>		
40 Featherstone Street London EC1Y 8RE		Tel 020 7490 4299 Fax 020 7490 4084 info@gmlarchitects.co.uk
PULHAM HOUSE CUCUMBER LANE HERTS LANE AL9 6J		MAR 2008  1:50@A3
DOG KENNEL PLANS AND ELEVATIONS	3338-04	A