

WINDOW	SIDE	FLOOR	TYPE
N.49	SOUTH	SECOND	SASH DOUBLE HUNG

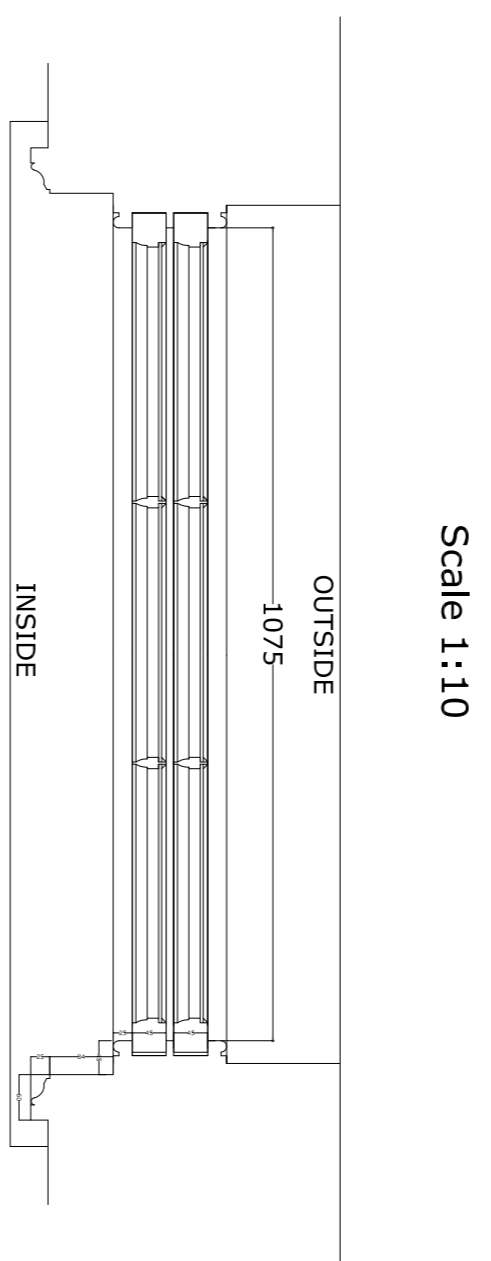

PLAN SECTION

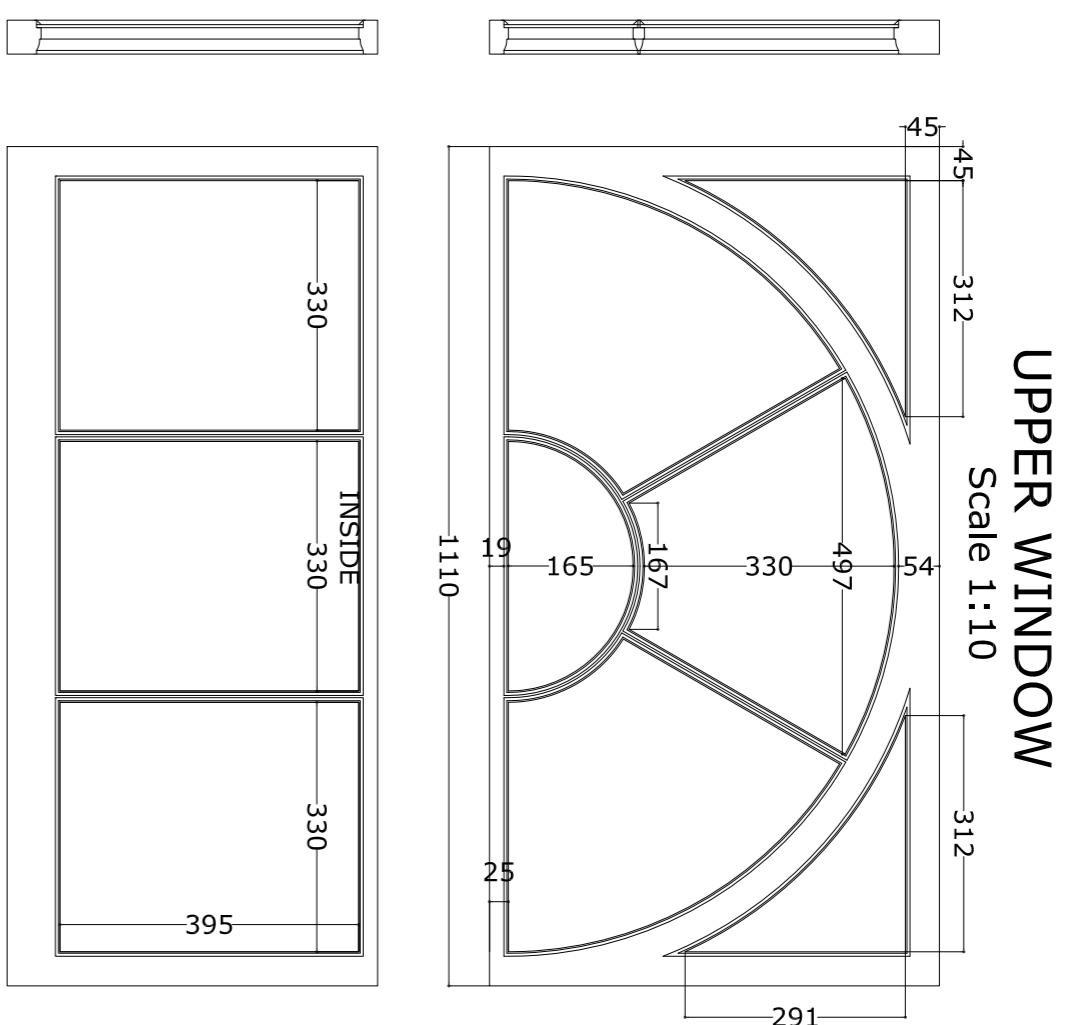
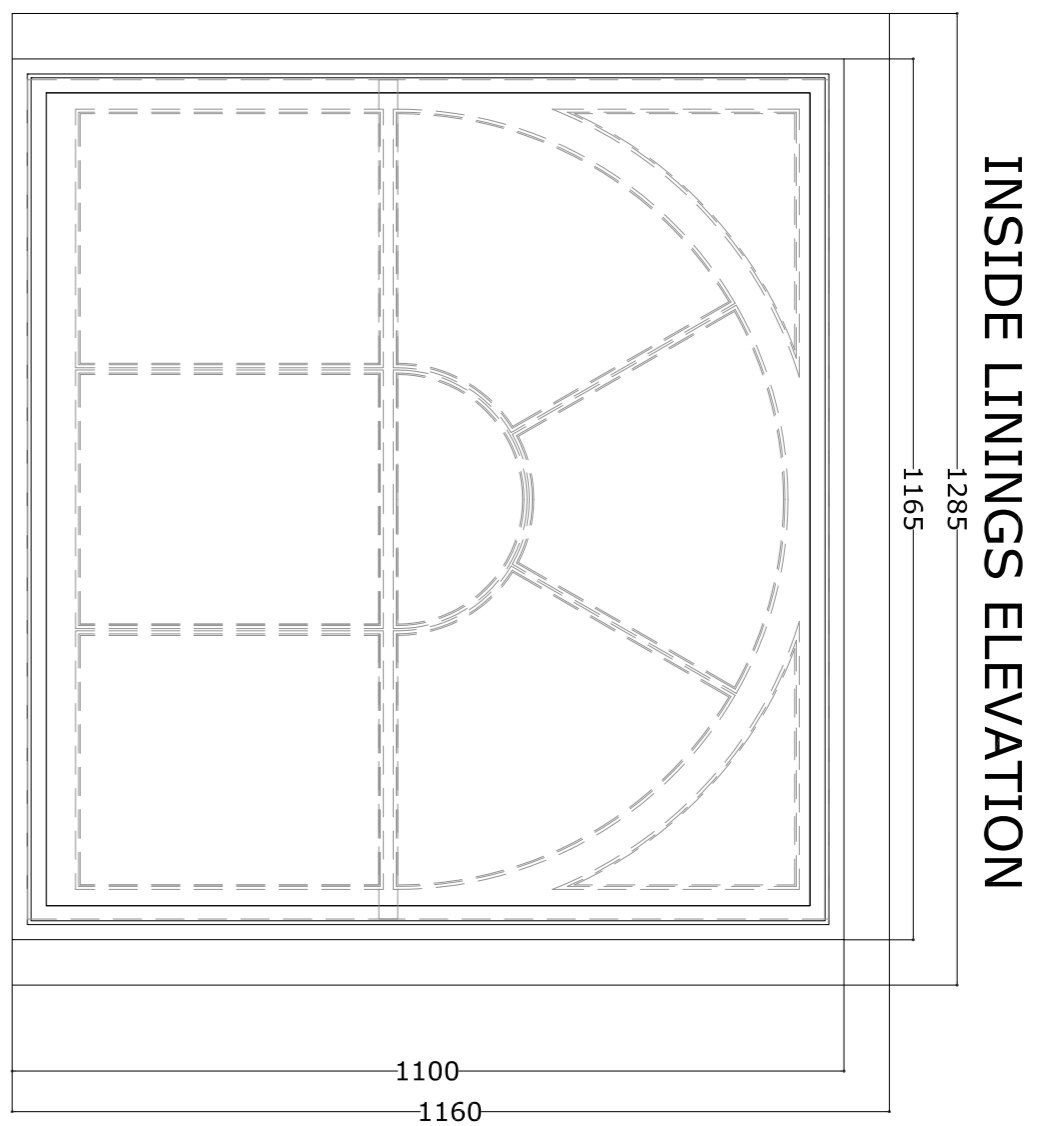
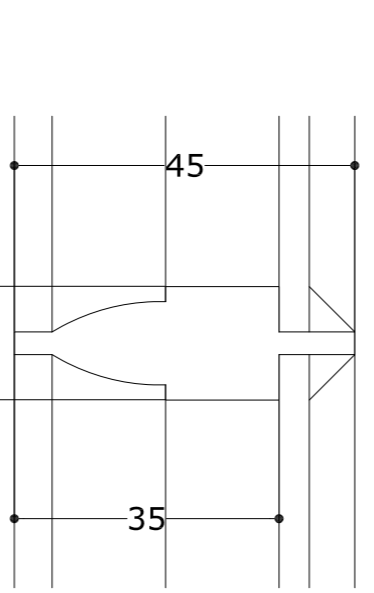

Scale 1:1
MUNTIN

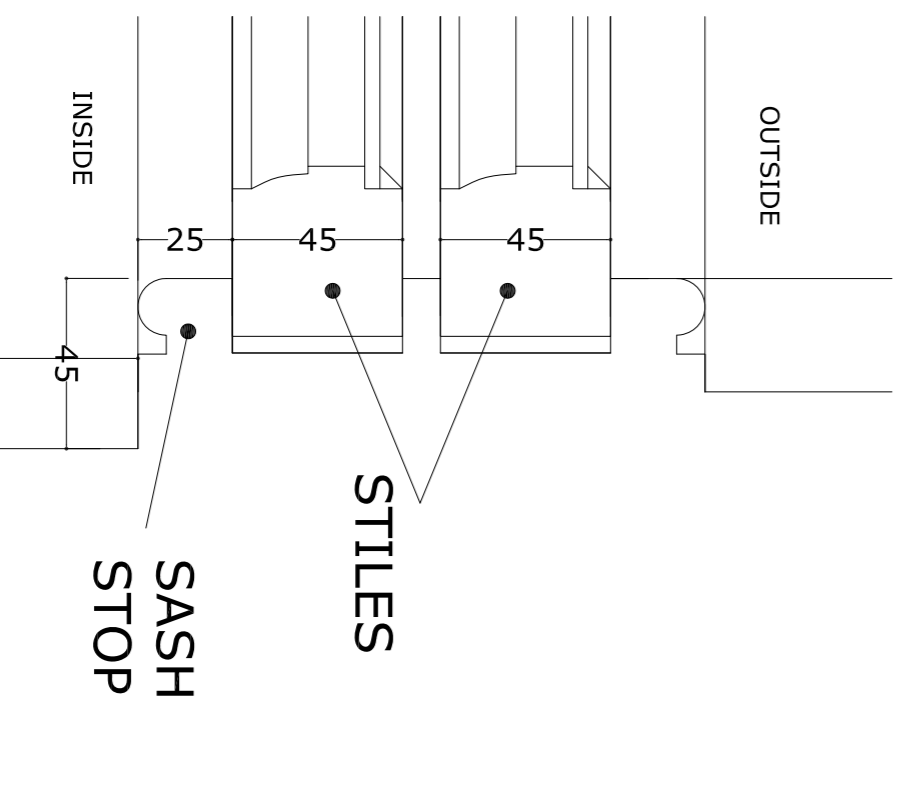

Scale 1:2
SASH STOP

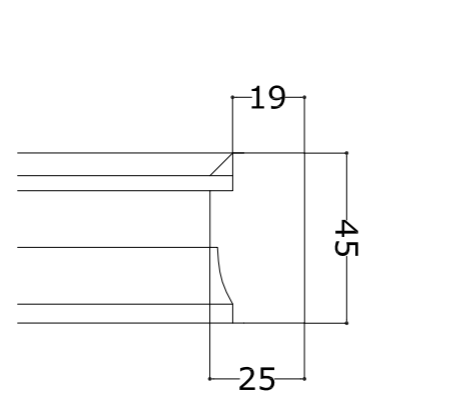

Scale 1:2
LOWER WINDOW

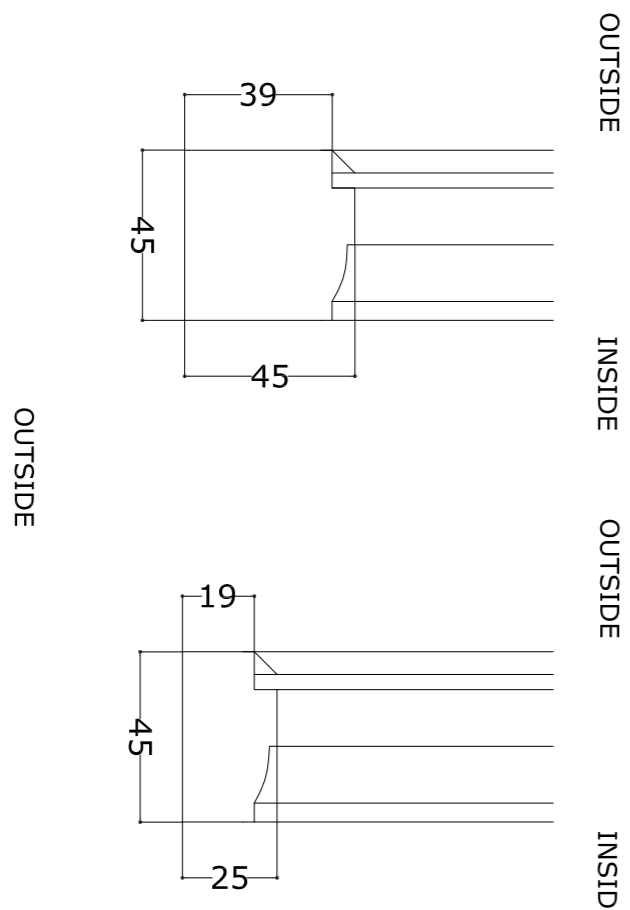

Scale 1:2
UPPER WINDOW



WINDOW	SIDE	FLOOR	TYPE
N.50/51	SOUTH	SECOND	SASH DOUBLE HUNG
N.52	WEST	SECOND	SASH DOUBLE HUNG

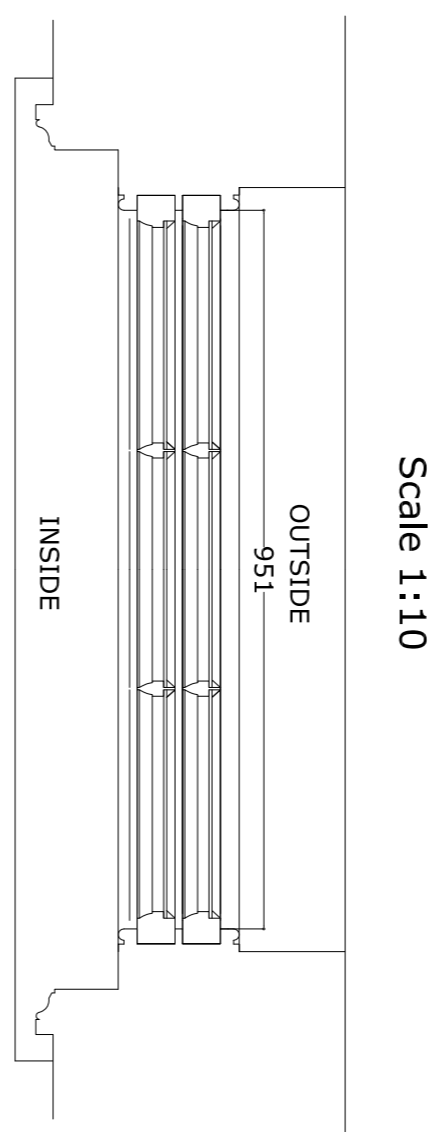
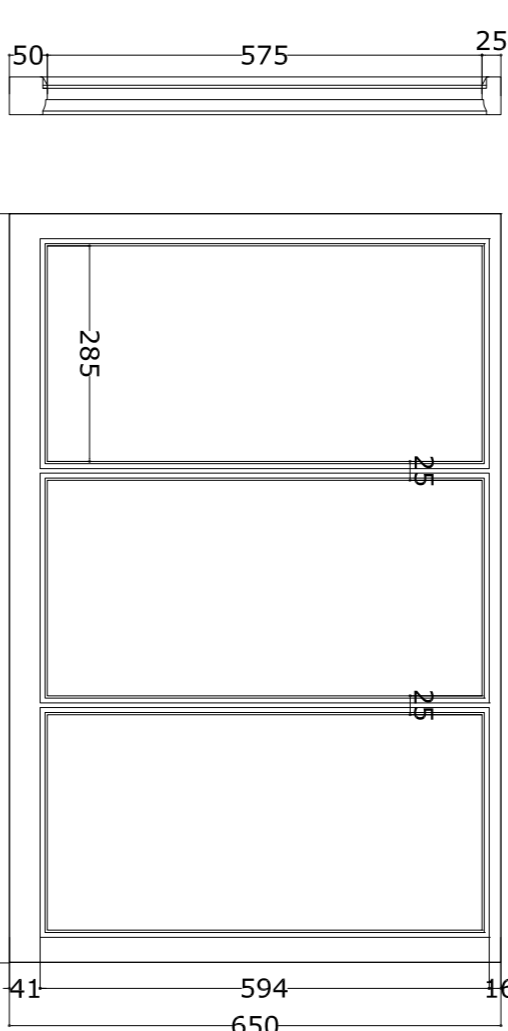
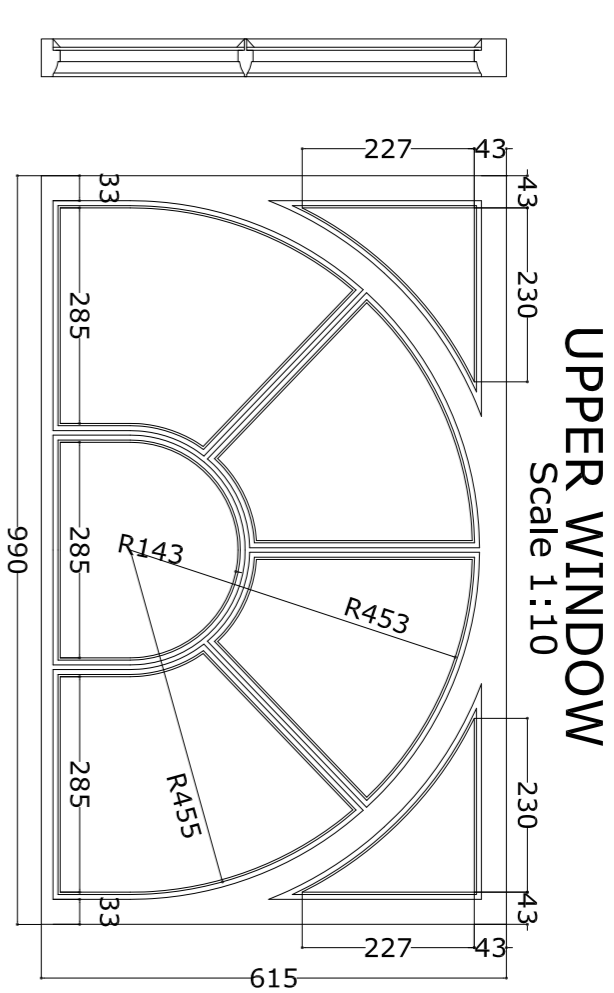
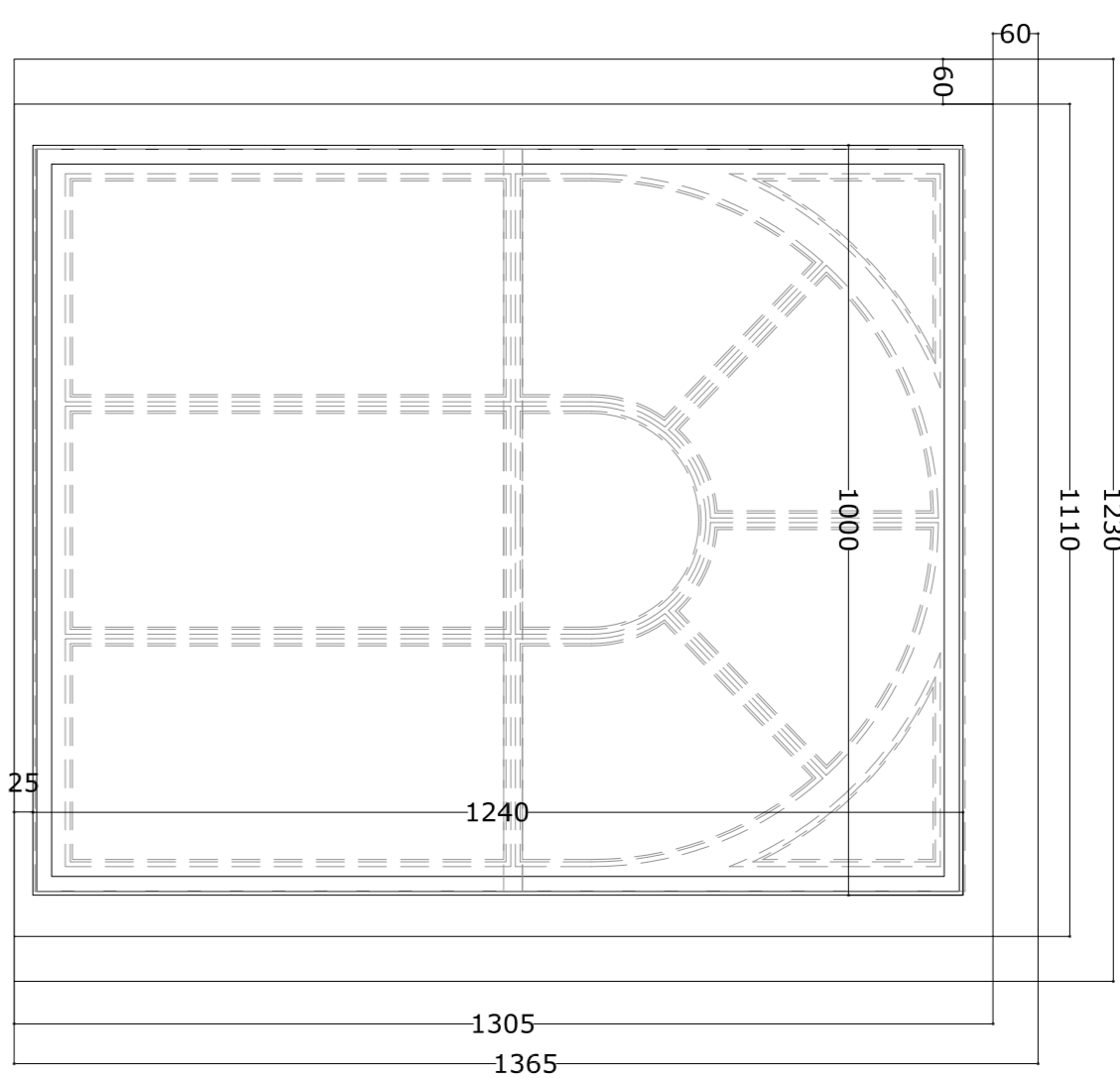

PLAN SECTION

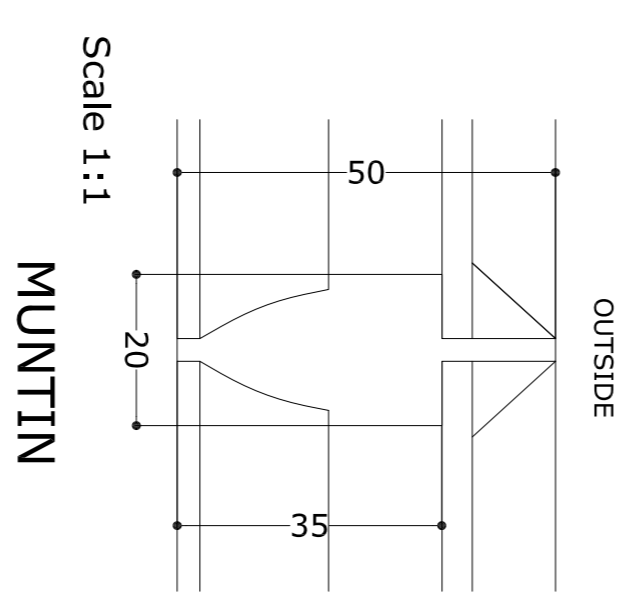

Scale 1:1
MUNTIN

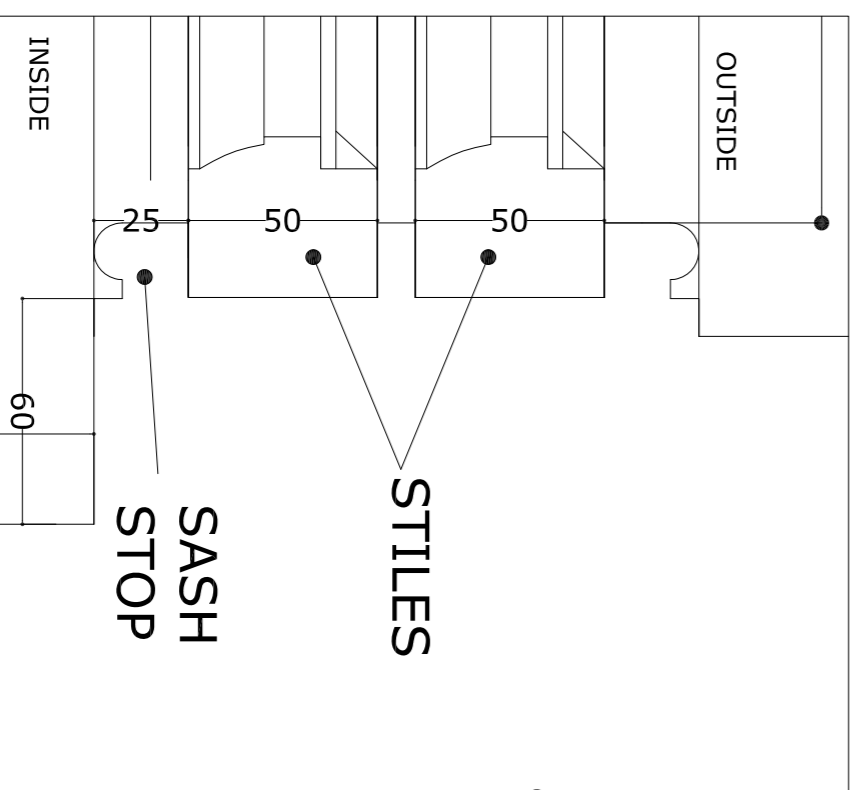

Scale 1:2
SASH STOP

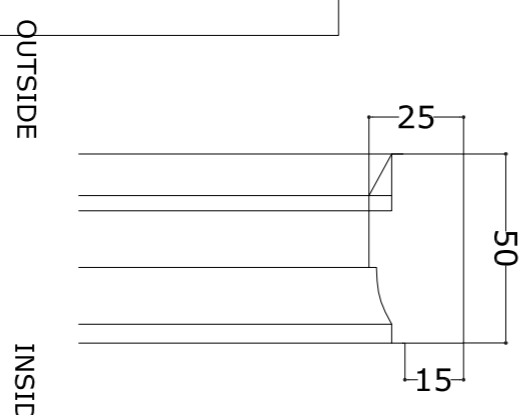

Scale 1:2
LOWER WINDOW

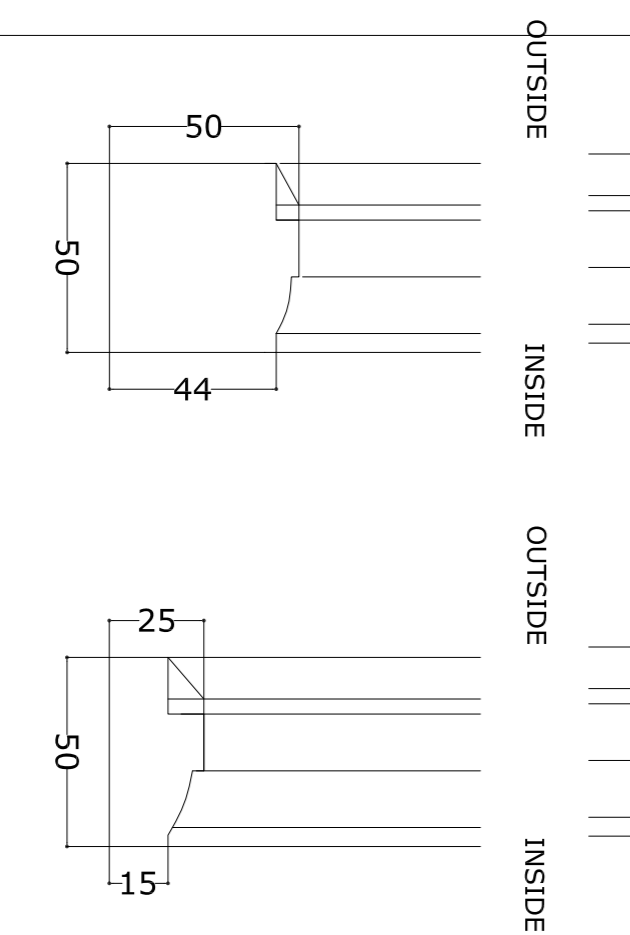

Scale 1:2
UPPER WINDOW



GENERAL NOTES

All dimensions to be checked on site and any discrepancy to be notified to the supervising officer.
No dimensions to be scaled from the drawings for construction purposes unless otherwise stated.
The site address of this drawing is the responsibility of the Architect and the client.
Building Regulation approval and work to commence before such approval.
Where this drawing is used for the work full specifications should be agreed with the client.
The client is responsible for ensuring that the work is carried out by a competent contractor.



REVISION	DESCRIPTION	BY	DATE

Salortia
CHARTERED ARCHITECTS
Unit 26 Cygnus Business Centre, Dalmeier Road NW10 2XA
Tel: +44 (020) 8451 7833 +44 (020) 8459 9600
Fax: +44 (020) 8451 3370
Email: info@salortia.co.uk website: www.salortia.co.uk

PROJECT
EXISTING WINDOWS - SURVEY -
MAIN HOUSE AT OSHWAL CENTRE
COOPERS LANE ROAD
NORTHAW HEARTFORDSHIRE EN6 4DG

DRAWING TITLE	WINDOWS 49-50-51-52
DATE	15.05.2015
SCALE	VARIOUS@A1, VARIOUS-1/2@A3
DRAWN BY	DP
CHECKED BY	LV
DRAWING NO.	6842-70-P0