

PLAN

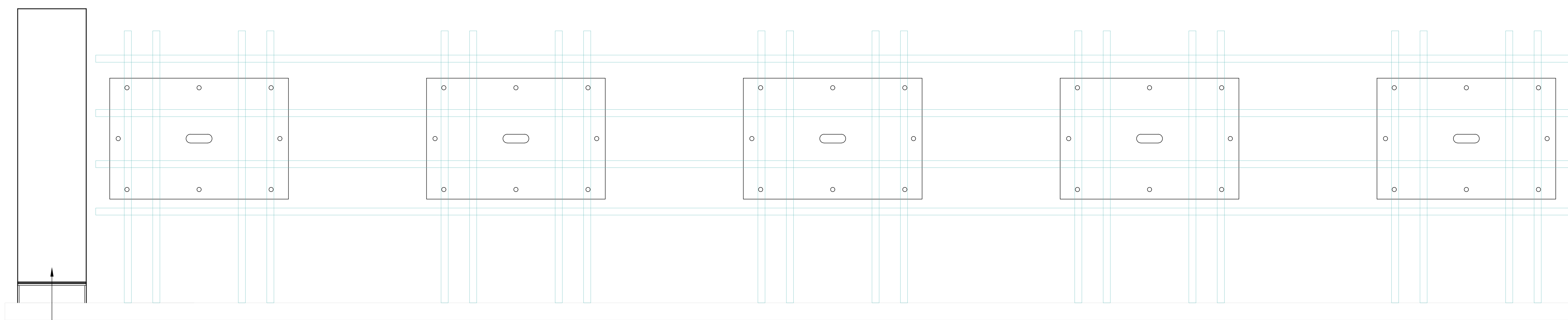

ELEVATION - SIDE

G99 relay and equipment

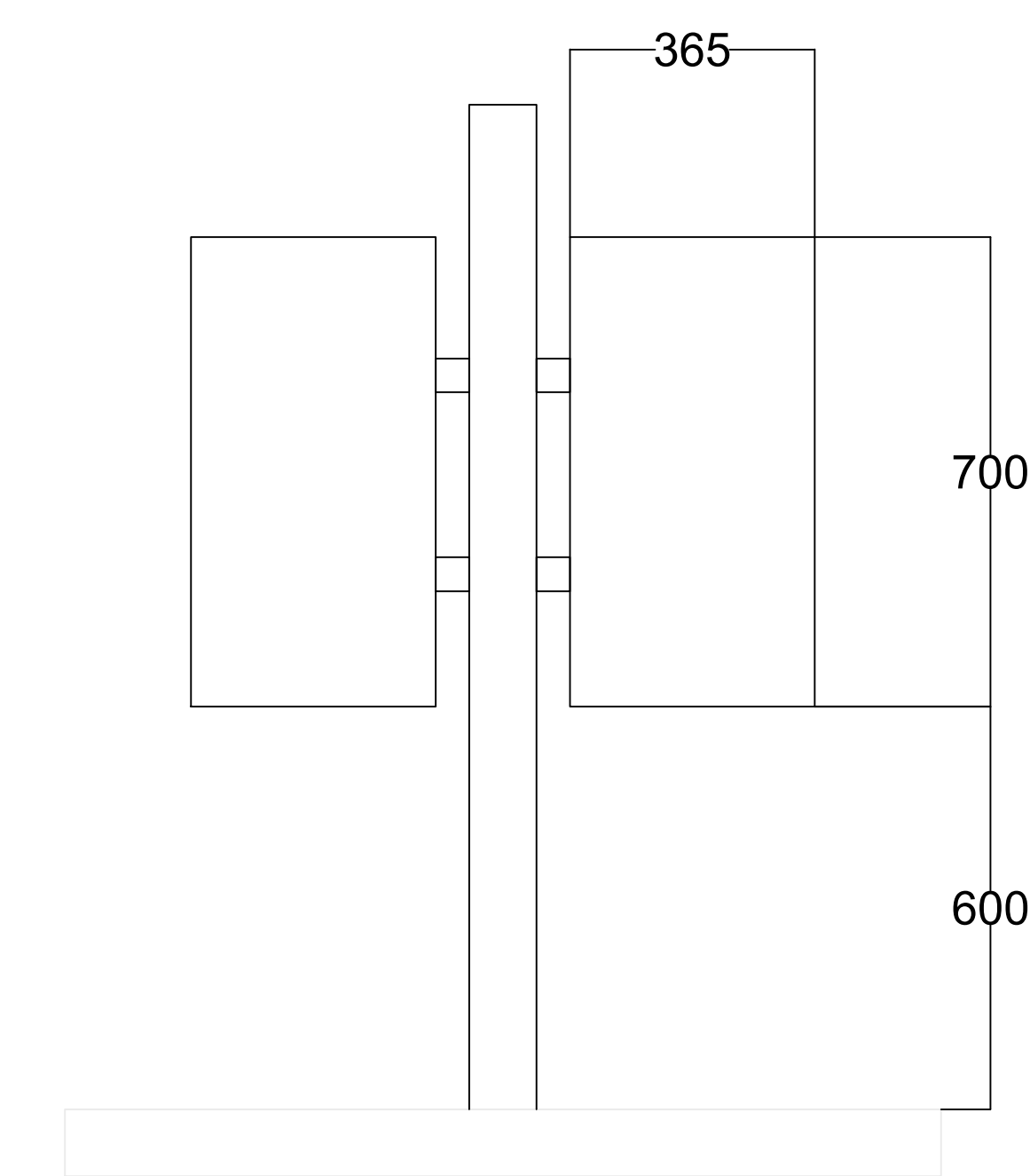

ELEVATION - END



HUAWEI SUN2000-100KTL-M1 INVERTER

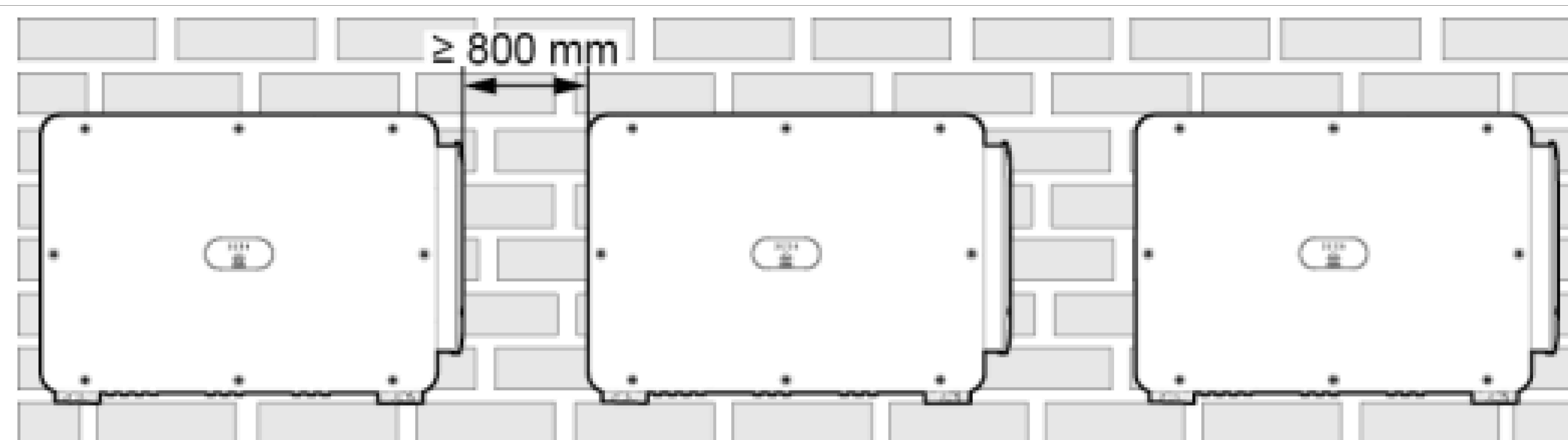

HUAWEI SUN2000-100KTL-M1 INVERTER SPACING



ENVISAGED INVERTER LOCATION

GENERAL NOTES

- USE MARKED DIMENSIONS
- DO NOT ALTER THIS BY HAND
- THIS DRAWING IS TO BE READ IN CONJUNCTION WITH ALL OTHER RELEVANT DRAWINGS AND SPECIFICATIONS.
- ANY APPARENT DRAFTING ERROR AND/OR DIFFERENCES BETWEEN OTHER DRAWINGS AND SPECIFICATIONS SHALL BE BROUGHT TO OUR ATTENTION
- ALL DIMENSIONS ARE IN MILLIMETERS UNLESS STATED OTHERWISE

PROJECT NOTES

- THIS DRAWING IS FOR INDICATIVE PURPOSES ONLY, BASED ON PRELIMINARY DESIGN INFORMATION. IT DOES NOT REPRESENT THE FINAL INSTALLATION. THE CONTRACTOR IS TO FURTHER DEVELOP THE DESIGN.

REV	DESCRIPTION	DRN	CHK	APR	DATE
V1	FOR PLANNING	SB	-	KB	10/21

PROJECT	OCADO, HATFIELD
ADDRESS	OCADO LTD, GYPSY MOTH AVENUE, HATFIELD HERTFORDSHIRE, AL10 9BD
TITLE	INDICATIVE INVERTER INFORMATION

DRG. NO	634-SYZ-DR-04
REVISION	V1
SCALE	1:10@ A0
DRAWN BY	SB
ISSUED	10/01/2021
CHECKED BY	-
APPROVED	KB



SYZYGY CONSULTING LIMITED
UNIT B6,
HATCHERS YARD,
9 TANNER STREET
LONDON
SE1 3LE
T: +44 (0) 20 7193 6040
www.szygyconsulting.eu