

Plan

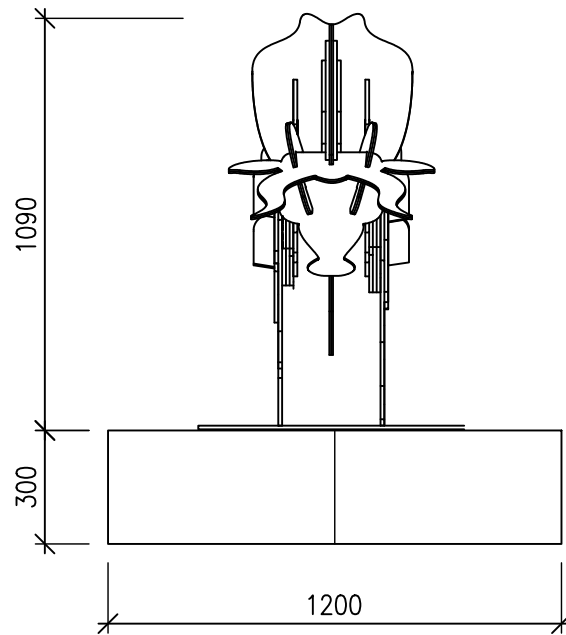

Rear Elevation

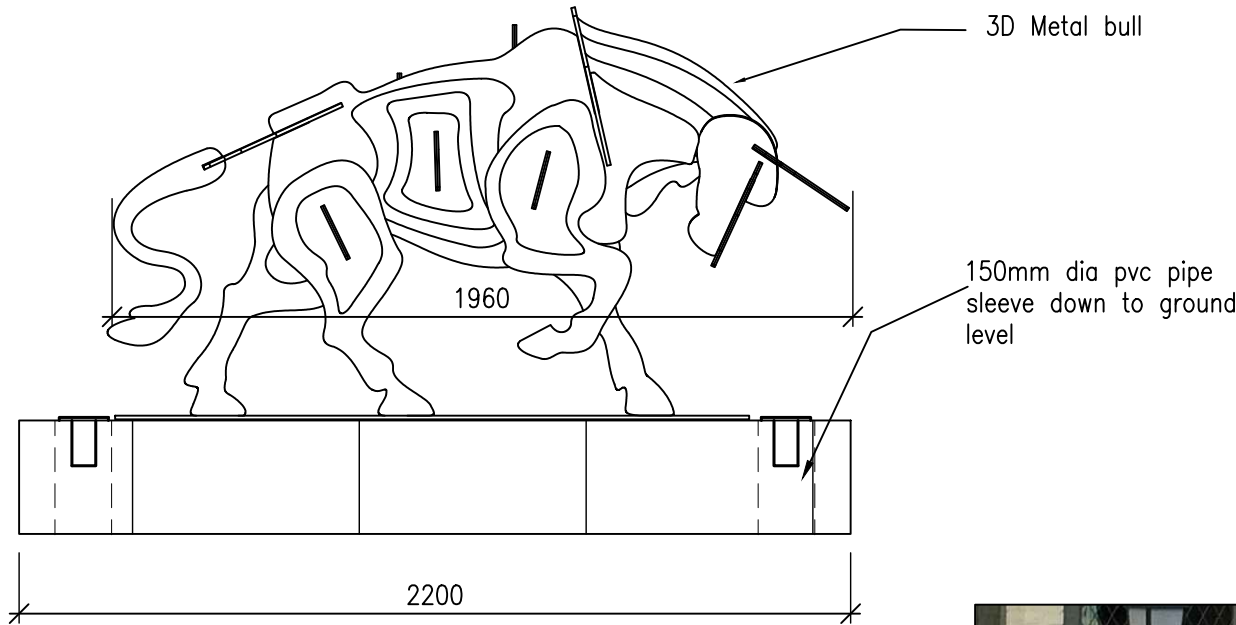

Side Elevation



Proposed Bull Statue - Image NTS

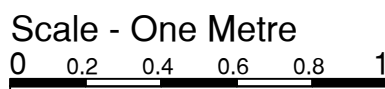

NOTES

The Contractor is to check and verify all building and site dimensions, levels and sewer invert levels at connection points before work starts. This drawing must be read with and checked against any structural or other specialist drawings provided.

The Contractor is to comply in all respects with the current Building Regulations whether or not specifically stated on these drawings.

This drawing is not intended to show details of foundation or ground conditions. Each area of ground relied upon to support the structure depicted must be investigated by the Contractor and suitable methods of foundation be provided.

This drawing is to be read in conjunction with all other standard Mitchells & Butlers specifications and documentation.

© This drawing remains the Copyright of Mitchells & Butlers Retail Limited.

Mitchells & Butlers Retail Limited
 27 Fleet Street
 Birmingham
 B3 1JP
 0870 609 3000



REVISIONS

REV	DESCRIPTION	BY	DATE

DESIGNCOALITION
 THE OLD MILL CASTLE STREET ONGAR ESSEX CM5 9JY

ADMIN@DESIGNCOALITION.CO.UK
 WWW.DESIGNCOALITION.CO.UK 01277 368000

PROJECT

Brookmans Park
 Hatfield

BRAND



BUN 209210

TITLE

Proposed Bull Statue
 Details

DRAWN DH	SCALE @ A3 1:20	DATE Oct 19
CHECKED	PROJECT/DRAWING NO 4532-701	REVISION